

Simplicity. Challenge. Lightness. Rhythm. Wonder. Time. For MDF Italia, design is about shaping matter with ideas, in the belief that there is no project without prior thought, and no thought without a diverse range of perspectives. More than simple products, the results of this process are thought forms.

book 1 Indoor

book 2 Outdoor

book 3 Contract

book 4 News

**mdf italia**

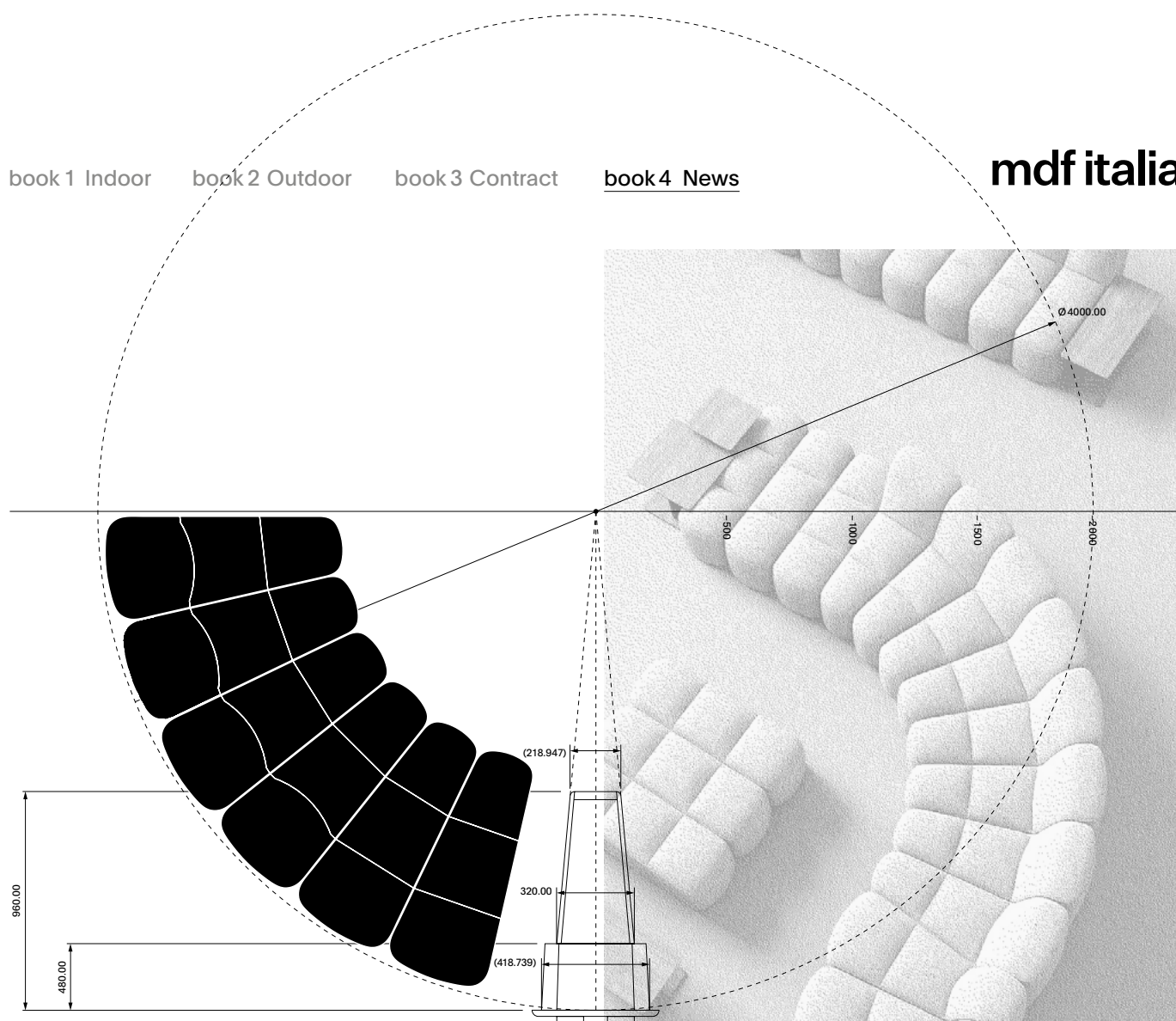

News book

## News book Index

Introduction	4
Products collection	6
Architecture	8
Responsible design	10
Designers	12
Concept house 1	16
Concept house 2	76
Technicals	110

## Sofas and armchairs

Array <sup>NEW!</sup>	24
Cantle <sup>NEW!</sup>	60
Cosy Curve	
Peggy <sup>NEW!</sup>	52

## Tables and coffee tables

Array low table <sup>NEW!</sup>	24
Bonnet <sup>NEW!</sup>	32
Flow low table	
Fossil	
Metodo	
NVL Table <sup>UPDATE</sup>	86
Rock Table collection	
Tense Collection <sup>UPDATE</sup>	42

## Systems and bookcases

Minima collection	
Pentagramma <sup>UPDATE</sup>	66
Random Wood	

## Chairs

Edo <sup>NEW!</sup>	46
Flow collection <sup>UPDATE</sup>	72
Neil collection	
Press collection <sup>UPDATE</sup>	92

## Stools and poufs

Cosy pouf	
Duetto <sup>NEW!</sup>	96
Fuji pouf	
Twig <sup>NEW!</sup>	106

## Beds and complements

Aluminium Bed  
Divide IT  
Frammenti  
Tatami  
Yale Bed

# News book

mdf italia

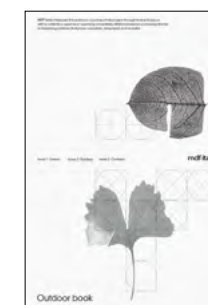

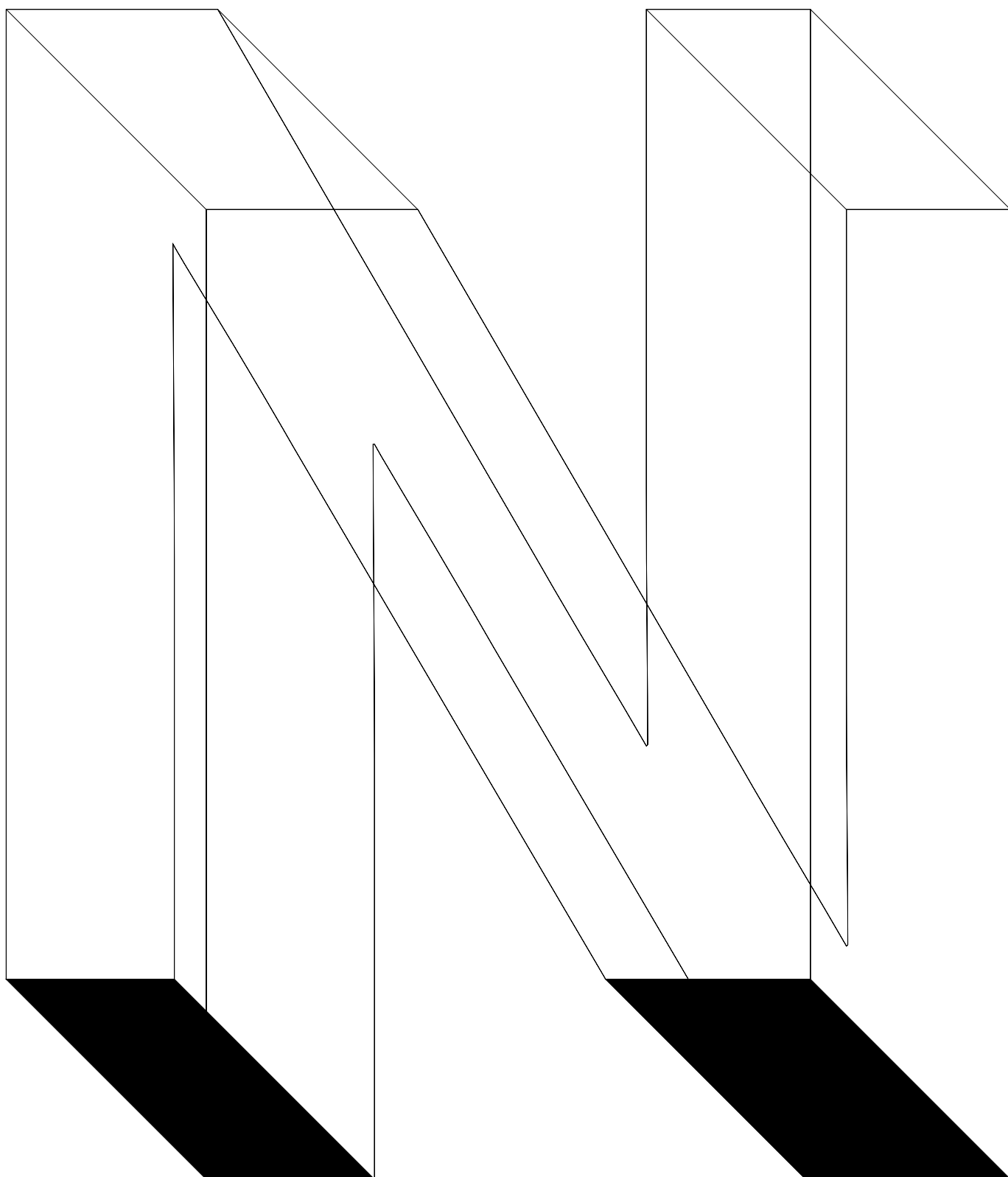

<sup>EN</sup> Is there really a need for another chair, another table, another armchair? We believe so, provided that every new product presented to the market has the ability to question what already exists and the audacity to challenge what is considered possible. This catalogue embodies our desire to always look ahead, allowing ourselves to be inspired by courageous minds, provocative ideas, innovative research, disciplines seemingly distant from our daily work. MDF Italia renews its canon, while remaining faithful to its principles: lightness, simplicity, wonder.

<sup>IT</sup> C'è davvero bisogno di un'altra sedia, di un altro tavolo, di un'altra poltrona? Noi pensiamo di sì, ammesso che ogni nuovo prodotto presentato al mercato abbia la capacità di interrogare l'esistente e la sfrontatezza di sfidare quello che oggi è considerato possibile. Questo catalogo incarna il nostro desiderio di guardare sempre avanti, lasciandoci contaminare da menti coraggiose, idee provocatorie, ricerche innovative, discipline apparentemente distanti dal nostro quotidiano. È il canone di MDF Italia che si rinnova, pur restando fedele ai pilastri che lo definiscono: leggerezza, semplicità, meraviglia.

Sofas and armchairs



Array



Cosy Curve



Cantle



Peggy

Systems and bookcases

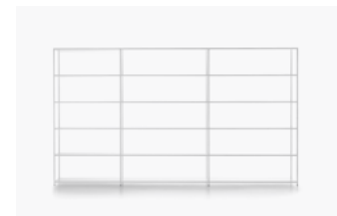

Minima collection



Pentagramma



Random Wood

Tables and coffee tables



Array low table



Bonnet



Flow Low Table



Fossil



Metodo



NVL Table



Rock Table collection



Tense Material Heritage

Chairs



Edo

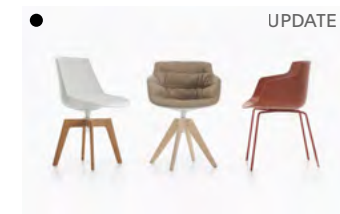

Flow collection



Neil collection



Press collection

Stools and poufs



Cosy pouf



Duetto



Fuji pouf



Twig

Beds and complements



Aluminium Bed



Divide IT



Yale Bed

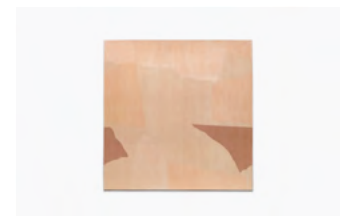

Frammenti



Tatami

# In dialogue with architecture

EN The new MDF Italia collection comes to life inside two houses designed by Pitsou Kedem. Characterised by clean lines and essential materials, the environments establish a harmonious dialogue with our products. This encounter based on a natural affinity is mediated by the styling of Cameranesi Pompili, responsible for giving the spaces a warm and intimate atmosphere, transforming them into contemporary refuges.

IT La nuova collezione di MDF Italia prende vita all'interno di due case progettate da Pitsou Kedem. Caratterizzati da pulizia delle linee ed essenzialità dei materiali, gli ambienti stabiliscono un dialogo armonioso con i nostri prodotti. Quest'incontro basato su un'affinità naturale è mediato dallo styling di Cameranesi Pompili, che avvolge gli spazi in un'atmosfera calda e intima, trasformandoli in rifugi contemporanei.



# Responsible design

EN MDF Italia creates objects that have the ambition to transcend fashion and last over time, a characteristic that leads them to be intrinsically sustainable. Today, this design attitude leads to a series of responsible choices in the field of materials, development and eco-design. In particular, we use wood exclusively from responsibly managed forests, flexible polyurethane of which more than half is made from recycled raw materials, and plastics that are either recycled or obtained from environmentally responsible processes. We design our products so that at the end of their life cycle they can be disassembled, thus facilitating a proper recycling process.

MDF Italia demonstrates its commitment to sustainability through ISO 14001 certification, internationally recognised as the reference standard for environmental management systems. A significant achievement, which marks the beginning of a dynamic path towards greater sustainability in our business processes.

IT MDF Italia realizza oggetti che hanno l'ambizione di trascendere le mode e durare nel tempo, una caratteristica che li porta a essere intrinsecamente sostenibili. Oggi, quest'atteggiamento progettuale sfocia in una serie di scelte responsabili nel campo dei materiali, della progettazione e dell'eco-design. In particolare utilizziamo legno proveniente esclusivamente da foreste gestite in modo responsabile, poliuretano flessibile realizzato con più della metà di materia prima riciclata e plastiche riciclate o ottenute da processi rispettosi dell'ambiente. Progettiamo i nostri arredi per far sì che al termine del loro ciclo di vita possano essere disassemblati, facilitando così un adeguato processo di riciclo.

MDF Italia dimostra il suo impegno per la sostenibilità attraverso la certificazione ISO 14001, riconosciuta a livello internazionale come lo standard di riferimento per i sistemi di gestione ambientale. Un traguardo significativo, che segna l'inizio di un percorso dinamico verso una maggiore sostenibilità nei nostri processi.



Benjamin Hubert<sup>1</sup>  
 Gilli Kuchik & Ran Amitai<sup>2</sup>  
 Gio Tiroto<sup>3</sup>  
 Jean Marie Massaud<sup>4</sup>  
 Marco Lavit<sup>5</sup>  
 Marialaura Irvine<sup>6</sup>  
 P.&M. Cazzaniga<sup>7 8</sup>  
 Pitsou Kedem<sup>9</sup>  
 Snøhetta<sup>10</sup>  
 Tommaso Caldera<sup>11</sup>  
 967arch<sup>12</sup>



EN For several years, MDF Italia has collaborated with some of the most talented Italian and international designers to create its collections. In this catalogue, the names of long-standing partners coexist with those of emerging talents or designers and studios that collaborate with our company for the first time. Heterogeneous in style, training and origin, these authors offer us a new look at who we are and challenge us to investigate thematic threads that will be decisive in the world of tomorrow.

IT Da diversi anni MDF Italia collabora con alcuni tra i più talentuosi designer italiani e internazionali per realizzare le sue collezioni. In questo catalogo, i nomi dei partner storici convivono con quelli di talenti emergenti o di designer e studi che si relazionano per la prima volta con la nostra azienda. Eterogenei per stile, formazione e provenienza, questi autori ci offrono uno sguardo nuovo su chi siamo e ci sfidano a indagare filoni tematici che saranno decisivi nel mondo di domani.

Designing

the future

## Benjamin Hubert

EN Benjamin Hubert is an award-winning British design entrepreneur. He founded LAYER in 2015 as a platform to represent the studio's multi-layered approach to design, with a focus on strategic thinking, inclusivity, and sustainability. Leading a team of 30 creatives, he remains firmly involved in the creative output of the London-based studio.

IT Benjamin Hubert è un pluripremiato imprenditore britannico del design. Ha fondato LAYER nel 2015 come piattaforma per mettere in pratica un approccio stratificato al design, con un focus sul pensiero strategico, sull'incisività e sulla sostenibilità. A capo di un team di 30 creativi, rimane saldamente coinvolto nella produzione creativa dello studio, che ha sede a Londra.

## Gilli Kuchik & Ran Amitai

EN Kuchik&Amitai Studio is an award-winning design studio founded in 2009 by Gilli Kuchik & Ran Amitai based in Herzliya, Israel. It creates products, objects and experiences across multidisciplinary fields, through a design process based on hands-on research and experimentation with materials and technologies.

IT Kuchik&Amitai è uno studio di design fondato nel 2009 da Gilli Kuchik e Ran Amitai con sede a Herzliya, in Israele. Crea prodotti, oggetti ed esperienze in diversi campi e discipline, attraverso un processo di progettazione basato sulla ricerca concreta e sulla sperimentazione di materiali e tecnologie.

## Gio Tiroto

EN Gio Tiroto is an Italian designer. After founding his design studio in 2010, he has developed interior, product and exhibition projects and has been in charge of the art direction for brands and companies, focusing on research and the synthesis between form and function.

IT Gio Tiroto è un designer italiano. Dopo aver fondato nel 2010 il suo studio di design, ha sviluppato progetti di interni, di prodotto ed espositivi, e si è occupato di direzione artistica per aziende, concentrandosi sulla ricerca e sulla sintesi tra forma e funzione.

## Jean Marie Massaud

EN Jean Marie Massaud's work is characterised by synthesis, reduction and lightness. His interests range from furniture to industrial products and accessories. In 2000 he opened Studio Massaud and expanded his activity to the fields of architecture and development strategy. With his creations he aims to shape the human being and the surrounding environment.

IT Il lavoro di Jean Marie Massaud è caratterizzato da sintesi, riduzione e leggerezza. I suoi interessi spaziano dal mobile al design di prodotto agli accessori. Nel 2000 ha aperto lo studio Massaud e ha esteso la sua attività ai settori dell'architettura e della strategia di sviluppo. Con le sue creazioni mira a plasmare l'uomo e l'ambiente circostante.

## Marco Lavit

EN Atelier Lavit is an architectural and design practice founded in Paris in 2014 by Marco Lavit. Architecture and design often proceed in parallel, striving to reach essential forms and a journey of timeless production. The humanistic approach of the studio covers a variety of projects that range from custom pieces, collectible design, product design and interior design to open air installations, private houses and eco-lodges.

IT Atelier Lavit è uno studio di architettura e design fondato a Parigi nel 2014 da Marco Lavit. L'architettura e il design procedono spesso in parallelo, alla ricerca di forme essenziali. L'approccio umanistico consente allo studio di affrontare progetti molto vari: pezzi personalizzati e da collezione, design di prodotto e di interni, installazioni all'aperto, case private ed eco-lodge.

## Marialaura Irvine

EN Studio Irvine is an architecture and design studio based in Milan, specialising in product design, creative direction and architectural spaces. Run by architect Marialaura Irvine, its work is characterised by a cross-disciplinary philosophy, an inclination towards all types of projects and a constant research on materials and surfaces.

IT Studio Irvine è uno studio di architettura e design con sede a Milano, specializzato in product design, direzione creativa e architettura. Diretto dall'architetto Marialaura Irvine, il suo lavoro è caratterizzato da una filosofia interdisciplinare, dall'inclinazione verso tutti i tipi di progetti e da una costante ricerca su materiali e superfici.

## P.&M. Cazzaniga

EN Piergiorgio Cazzaniga, a talented Italian designer, inherited the art from his carpenter father. With over 30 years of experience in the industry, he founded his own studio in 1991. Michele Cazzaniga is a renowned designer and architect. In 1998, he joined Piergiorgio's studio, focusing on interior design. Together they have created numerous iconic works, characterized by pure forms, functionality, and impeccable attention to detail.

IT Piergiorgio Cazzaniga, designer italiano di talento, ha ereditato l'arte dal padre ebanista. Con oltre 30 anni di esperienza nel settore, nel 1991 fonda il suo studio. Michele Cazzaniga è un rinomato designer e architetto. Nel 1998 si unisce allo studio di Piergiorgio, concentrandosi sul design degli interni. Insieme hanno creato numerose opere iconiche, caratterizzate da forme pulite, funzionalità e una precisione impeccabile nei dettagli.

## Pitsou Kedem

EN Founded in 2000 in Tel Aviv, Pitsou Kedem Architects is responsible for the design and planning of numerous projects around the world, characterised by a contrast between simple and clean external volumes, and complex and rich internal sections. The studio's design language is based on the modernist style. In 2020, Pitsou Kedem designed MDF Italia's new corporate showroom.

IT Fondato nel 2000 a Tel Aviv, Pitsou Kedem Architects è responsabile della progettazione e pianificazione di numerosi progetti in tutto il mondo, caratterizzati da un contrasto tra volumi esterni semplici e puliti e sezioni interne ricche e complesse. Il linguaggio dello studio si fonda sullo stile modernista. Nel 2020, Pitsou Kedem ha disegnato il nuovo showroom aziendale di MDF Italia.

## Snøhetta

EN Snøhetta is a transdisciplinary, dialogue-driven practice operating in a wide array of fields including architecture, landscape, interiors, art, product design, graphic and digital design, often integrating a combination of interests across its projects. With more than 350 employees across nine regional studios, Snøhetta's approach is informed by environmental and cultural sensitivity.

IT Snøhetta è uno studio transdisciplinare e orientato al dialogo che si occupa di architettura, paesaggio, interni, arte, design del prodotto, design grafico e digitale, integrando spesso una combinazione di interessi nei suoi progetti. Con oltre 350 dipendenti distribuiti in nove studi in tutto il mondo, Snøhetta ha un approccio improntato alla sensibilità culturale e ambientale.

## Tommaso Caldera

EN Tommaso Caldera is an Italian designer. After collaborating with studios in Milan and New York, he presented his first creations at the Salone del Mobile in Milan in 2012. In his Pavia-based studio, he works on product design in all its forms for Italian and international companies. His articles on design and culture have appeared in Italian and international magazines.

IT Tommaso Caldera è un designer italiano. Dopo aver collaborato con alcuni studi a Milano e New York, nel 2012 ha presentato al Salone del Mobile di Milano le sue prime creazioni. Nel suo studio con sede a Pavia si occupa di design del prodotto in tutte le sue declinazioni per aziende italiane ed internazionali. I suoi articoli su design e cultura sono apparsi su riviste italiane e internazionali.

## 967arch

EN Founded by Cesare Chichi and Stefano Maestri, 967arch offers a wide range of architectural works and interior design concepts, both in Italy and abroad, in collaboration with a highly qualified team of architects and designers, able to work on different scale projects with great attention to detail. Since 2021, 967arch has been collaborating with MDF Italia to develop products and catalogues.

IT Fondato da Cesare Chichi e Stefano Maestri, 967arch fornisce una vasta gamma di servizi architettonici e concept di interior design, sia in Italia che all'estero, in collaborazione con un team altamente qualificato di architetti e designer, in grado di lavorare su progetti di diversa scala con grande attenzione ai dettagli. Dal 2016, 967arch collabora con MDF Italia per lo sviluppo di prodotti e cataloghi.

# The

# designers



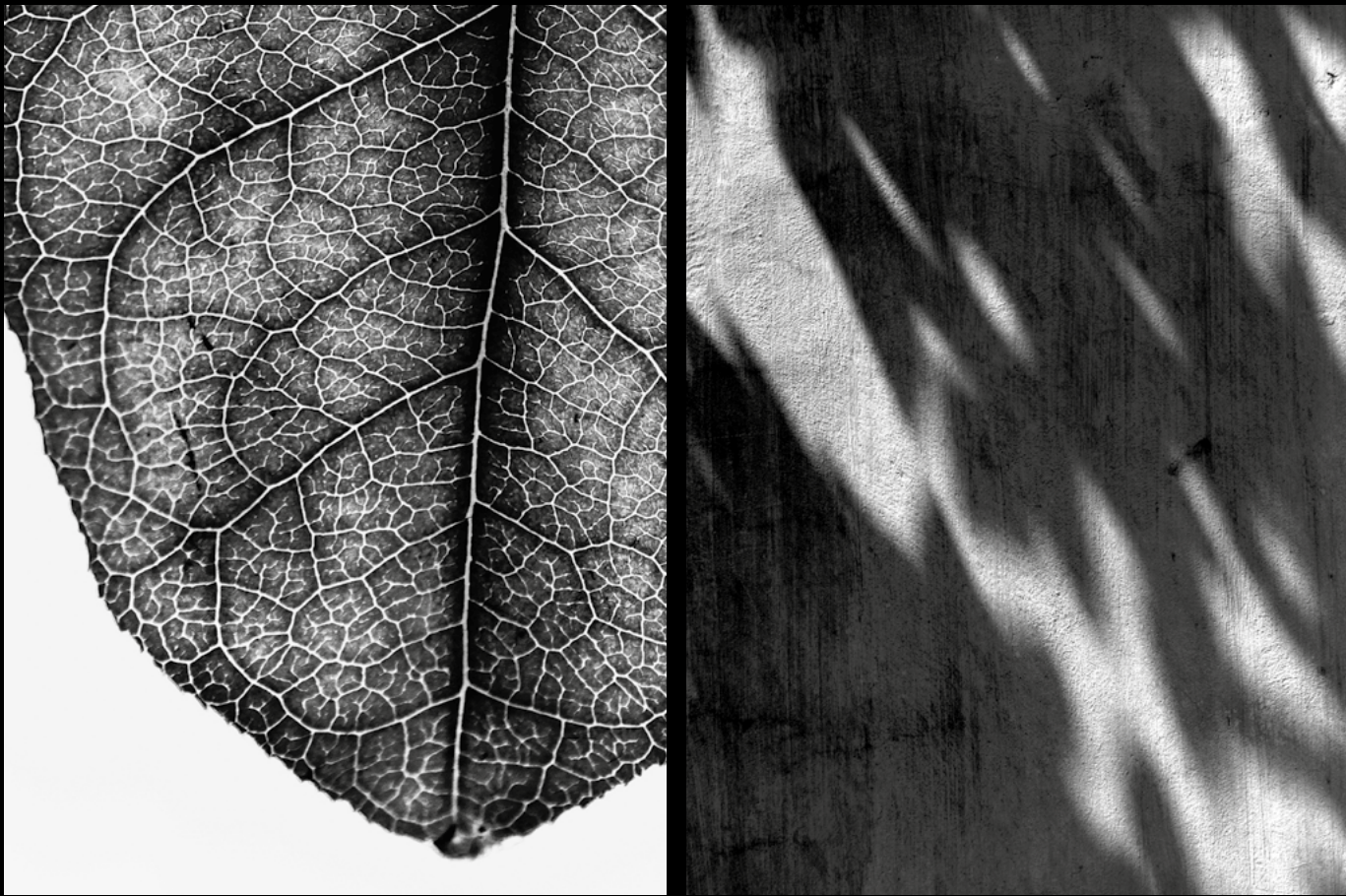

EN Clean lines and warm-tones coexist in this villa designed by Pitsou Kedem. The ground floor communicates directly with the front and rear gardens, creating a sense of constant dialogue between architecture and nature, between the light filtering through the windows and the geometric perspectives of the rooms, between the plaster walls and the natural resin floors.

IT Linee nette e tonalità calde convivono in questa villa progettata da Pitsou Kedem. Il piano terra comunica direttamente con i giardini anteriore e posteriore, creando la sensazione di un dialogo costante tra architettura e natura, tra la luce che filtra dalle vetrate e le prospettive geometriche degli ambienti, tra le pareti in intonaco materico e i pavimenti in resina naturale.

# A villa in nature

Concept house  
Architecture

N.1  
Pitsou Kedem

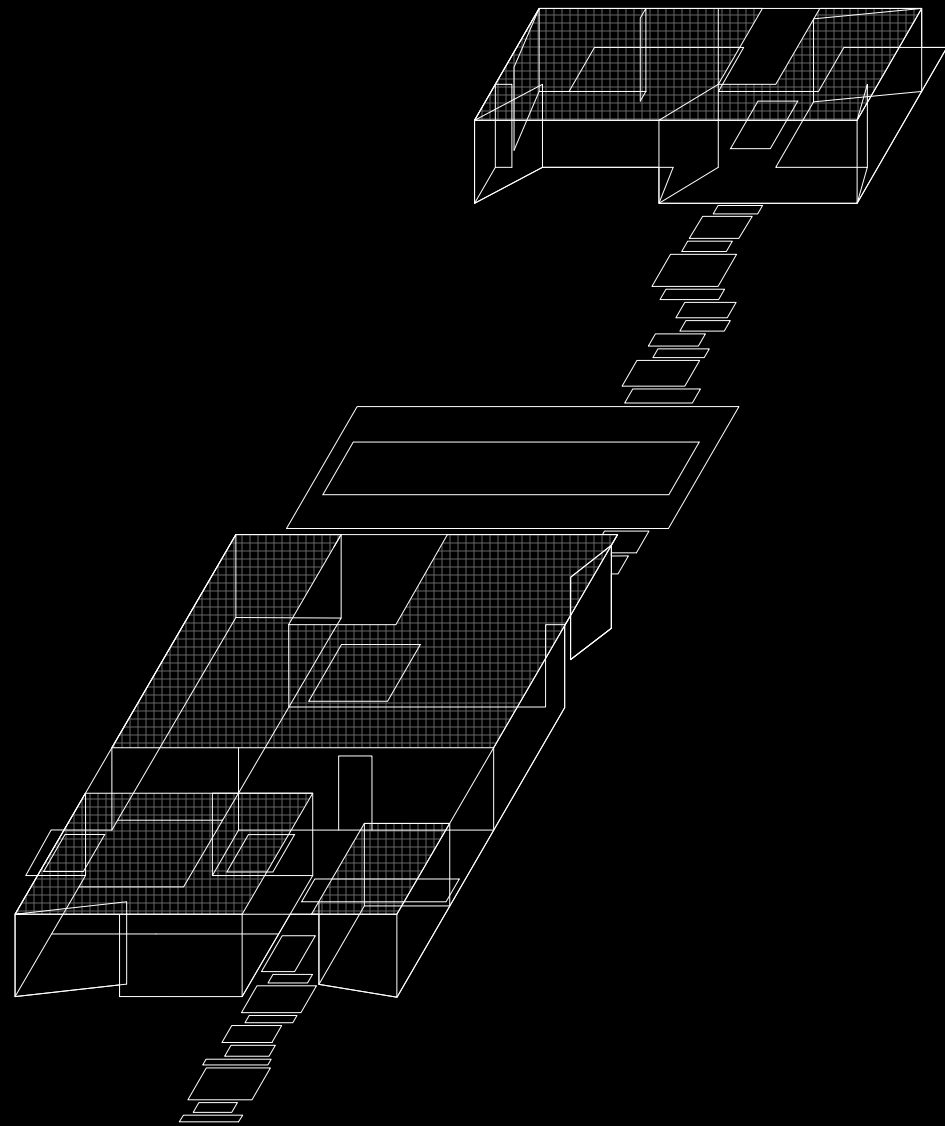



UPDATE

Pentagramma



NEW!

Array



Fossil



NEW!

Peggy



← The Array collection is developed from both a micro and macro perspective and it is suitable for residential and contract contexts.





NEW!

Peggy



Fossil



NEW!

Array



UPDATE

Pentagramma

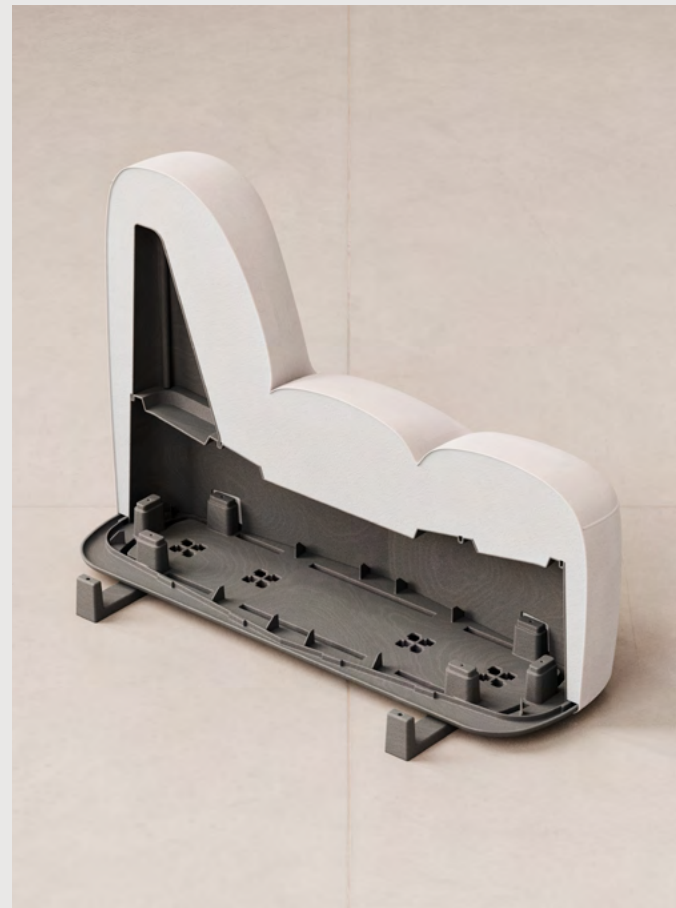

EN Array is a sofa system designed by Snøhetta to offer maximum flexibility and comfort. It represents a new approach to sofa design and construction, with the goal of reducing environmental impact, achieving customised living solutions, and simplifying logistics. To this end, it introduces small modules, which permit a variety of layouts, are easy to transport, and can be easily disassembled and reassembled for replacement or recycling. The concept of comfort extends to the entire supply chain, moving beyond its ergonomic component.

The robust injection-moulded base made of recycled plastic, which leaves a hollow core inside, minimises the use of material. The bio-foam in the seat and back is moulded for optimal comfort. The fabric cover is also available in recycled polyester. The Array collection is developed from both a micro and macro perspective and is suitable for residential and contract contexts.

IT Array è un sistema di divani progettato da Snøhetta per offrire massima flessibilità e comfort. Rappresenta un nuovo approccio alla concezione del divano e alla sua costruzione, con l'obiettivo di ridurre l'impatto ambientale, ottenere soluzioni abitative personalizzate, e semplificare la logistica. Introduce a questo scopo moduli piccoli, che consentono di generare una varietà di configurazioni, sono facili da trasportare, e possono essere smontati e rimontati agevolmente per la sostituzione o il riciclaggio. Il concetto di comfort è esteso a tutta la filiera, andando oltre la sua componente ergonomica.

La robusta base stampata a iniezione in plastica riciclata, che lascia un nucleo cavo all'interno, minimizza l'uso di materiale. La bio-schiuma nel sedile e nello schienale è modellata per massimizzare il comfort. La copertura tessile è disponibile anche in poliestere riciclato. La collezione Array è sviluppata considerando allo stesso tempo una prospettiva sia micro che macro e si adatta a contesti residenziali e contract.

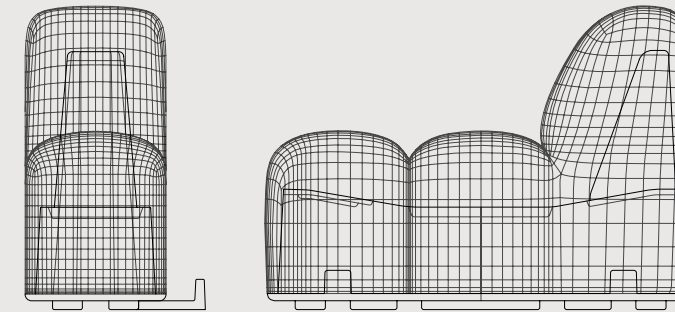

## Array

## Sofa System

Designed by Snøhetta

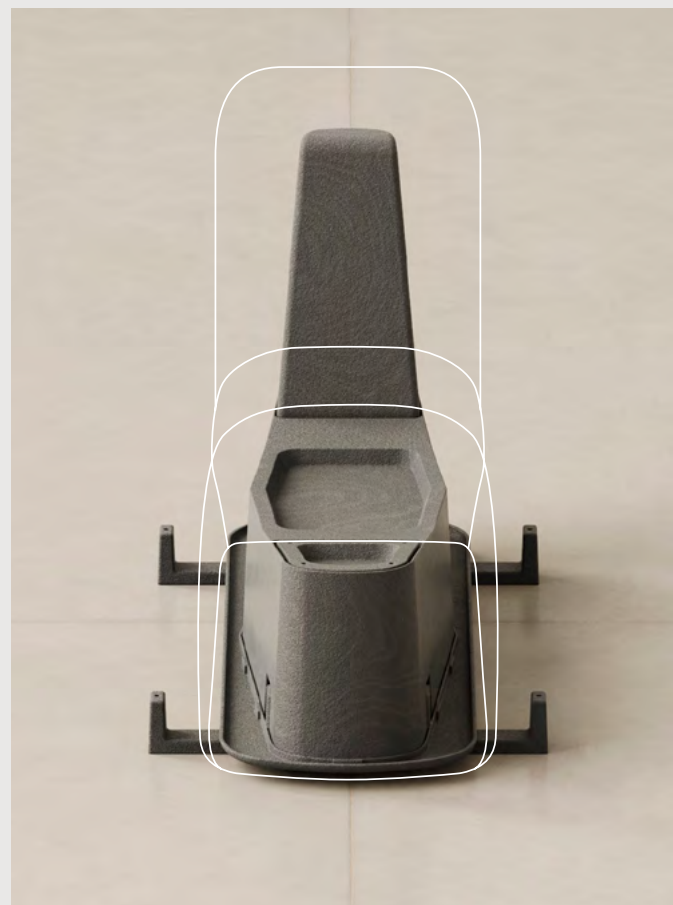

Straight module with backrest	L32 D96 H68 seat H40	A
Module for external curve	L40 D96 H68 seat H40	B
Module for inside curve	L40 D96 H68 seat H40	C
Straight pouf module	L32 D96 H40	D
Curved pouf module	L40 D96 H40	E
Straight armrest module	L32 D96 H50	F
Curved armrest module	L40 D96 H50	G
Coffee table S	L32 D32 H44	S
Coffee table M	L45 D45 H39	M
Coffee table L	L74 D32 H34	L
Side table	L23 D52 H23	T

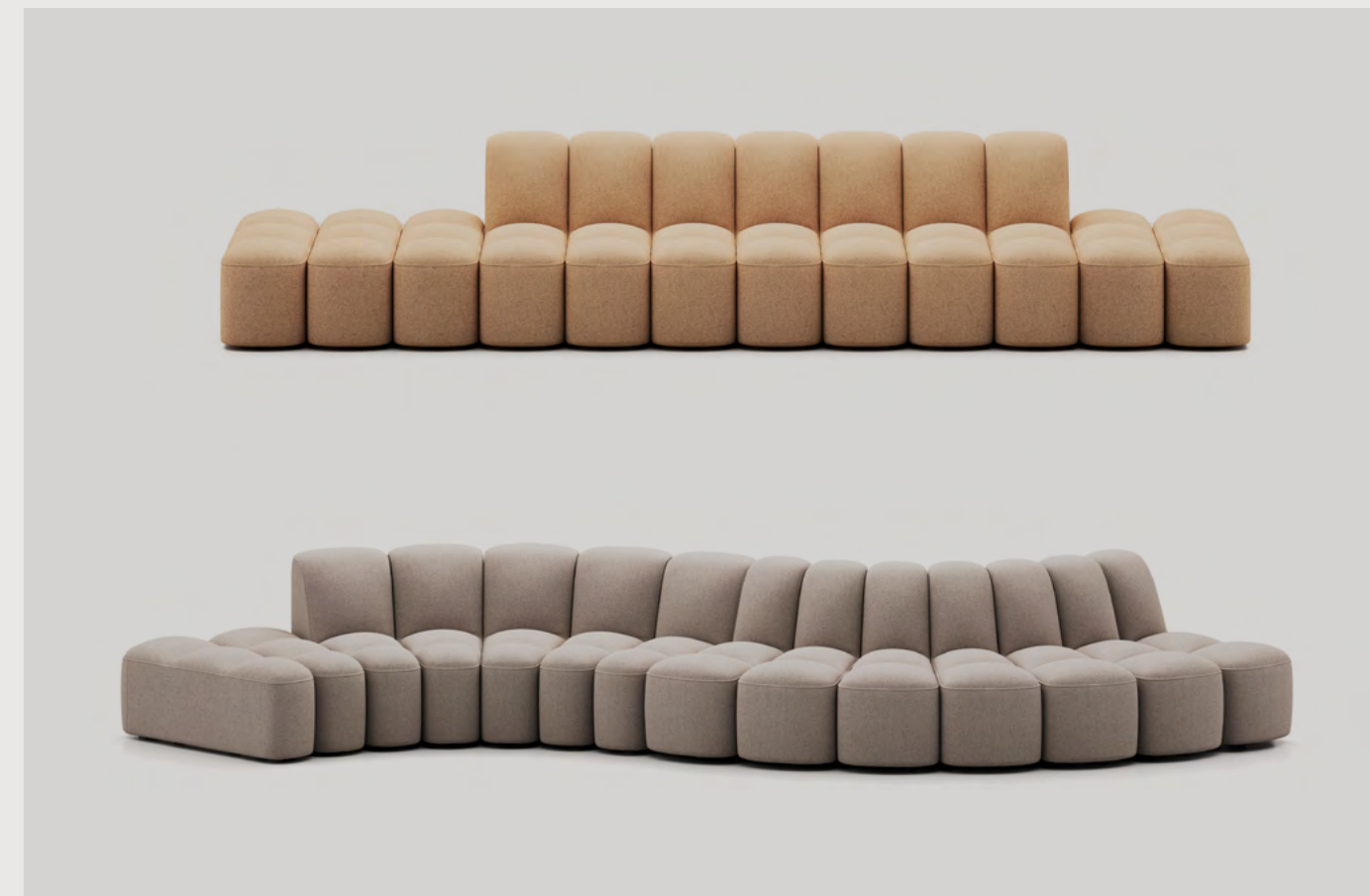
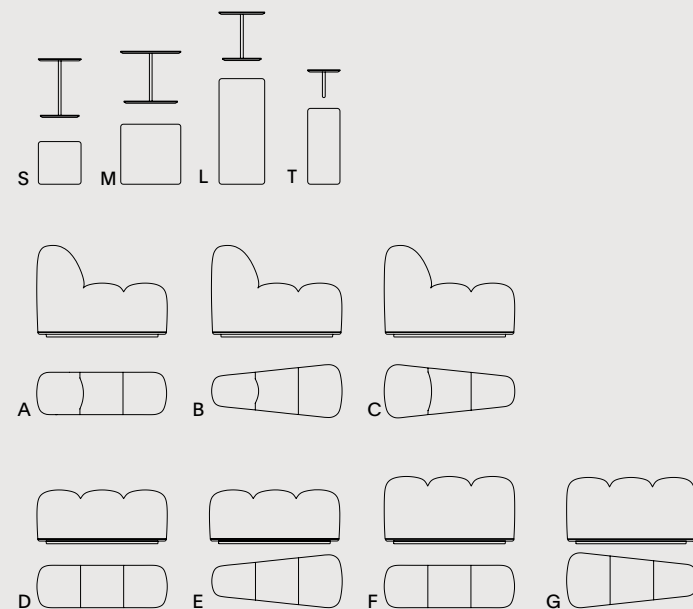

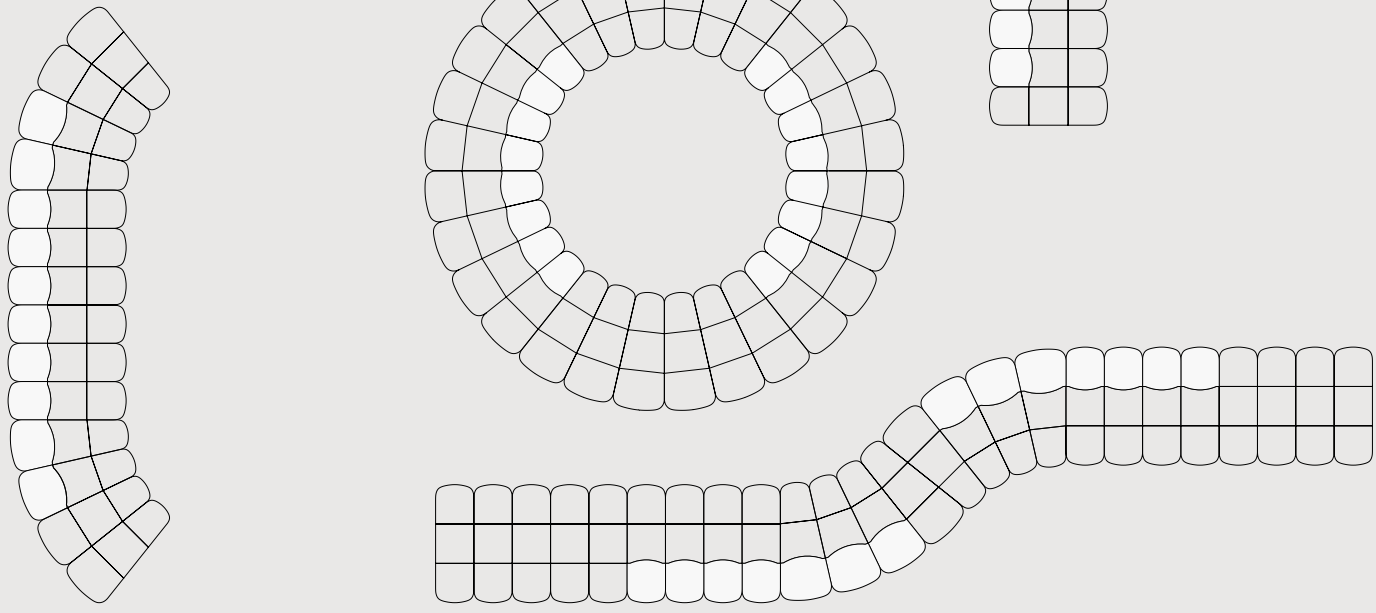

## Array

## Sofa System

Designed by Snøhetta

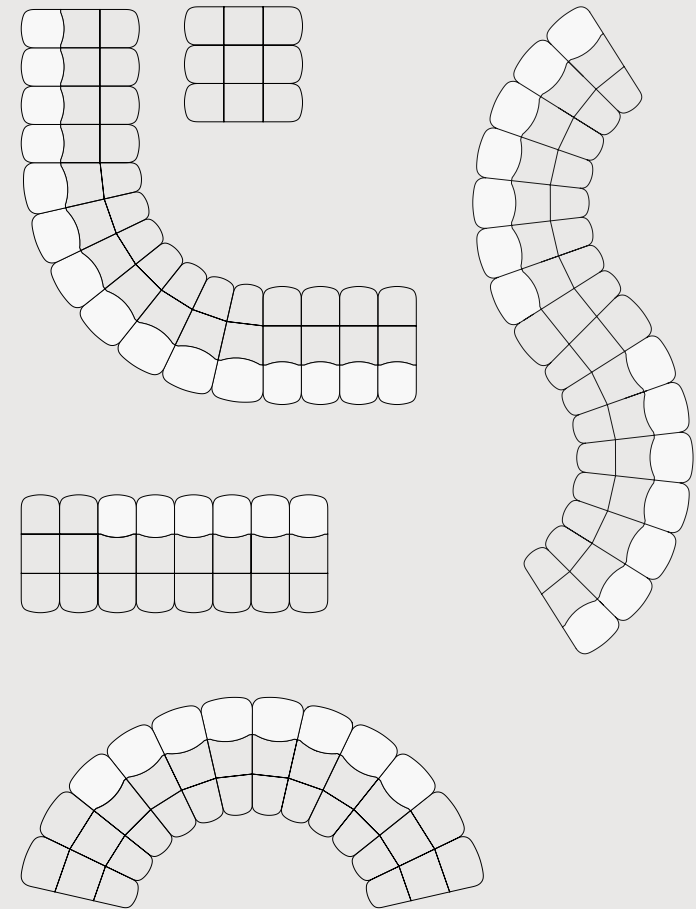



→ The tables in the Bonnet family interpret the theme of soft, rational forms with architectural élan.



Bonnet

30



Press collection

Concept house

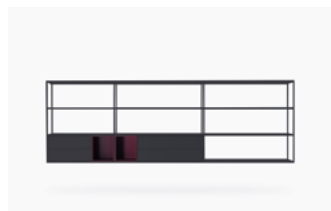

Minima 3.0 Hanging

N.1





EN The tables in the Bonnet family interpret the theme of soft, rational forms with architectural élan, introducing a touch of femininity into the MDF Italia collection that invites unprecedented social experiences. The legs, which resemble smoothed blades, rise up and embrace the table top with which they create a dynamic tension. The simple but bold asymmetrical and unusual shapes of the top have a strong personality that softens formal rigour with what the designer, Marialaura Irvine, calls a "radical whisper". When combined, these tables can create unexpected compositions. The result of experiments with materials and colours, the sophisticated single-material finishes made with Coccioperla (a mixture of mortar, aggregates and crushed mother-of-pearl) give the surfaces a tactile, brilliant and vivid aura.

IT I tavoli della famiglia Bonnet interpretano con élan architettonico il tema delle forme morbide e razionali, introducendo all'interno della collezione di MDF Italia un tocco di femminilità che invita a inedite esperienze di convivialità. Le gambe, simili a lame addolcite, sveltano e accolgono il piano del tavolo con cui creano una tensione dinamica. Le sagome asimmetriche e inusuali del piano, semplici ma decise, sono caratterizzate da una forte personalità che smussa il rigore formale con quel che la designer, Marialaura Irvine, definisce un "radical whisper". Combinati tra loro, questi tavoli possono creare configurazioni inaspettate. Frutto di sperimentazioni con materiali e colori, le sofisticate finiture mono-materiche in Coccioperla (una miscela di malta, inerti e madreperla tritata) conferiscono infine alle superfici un'aura tattile, brillante e vivida.



## Bonnet

## Table

Designed by Marialaura Irvine



Shaped table	L300 D150	A
H73	L230 D160	B
	L240 D115	C
	L180 D130	D
	L140 D160	E
Rectangular table	L300 D120	F
H73	L240 D100	G
	L200 D100	H
Square table	L120 D120	I
H73	L150 D150	J

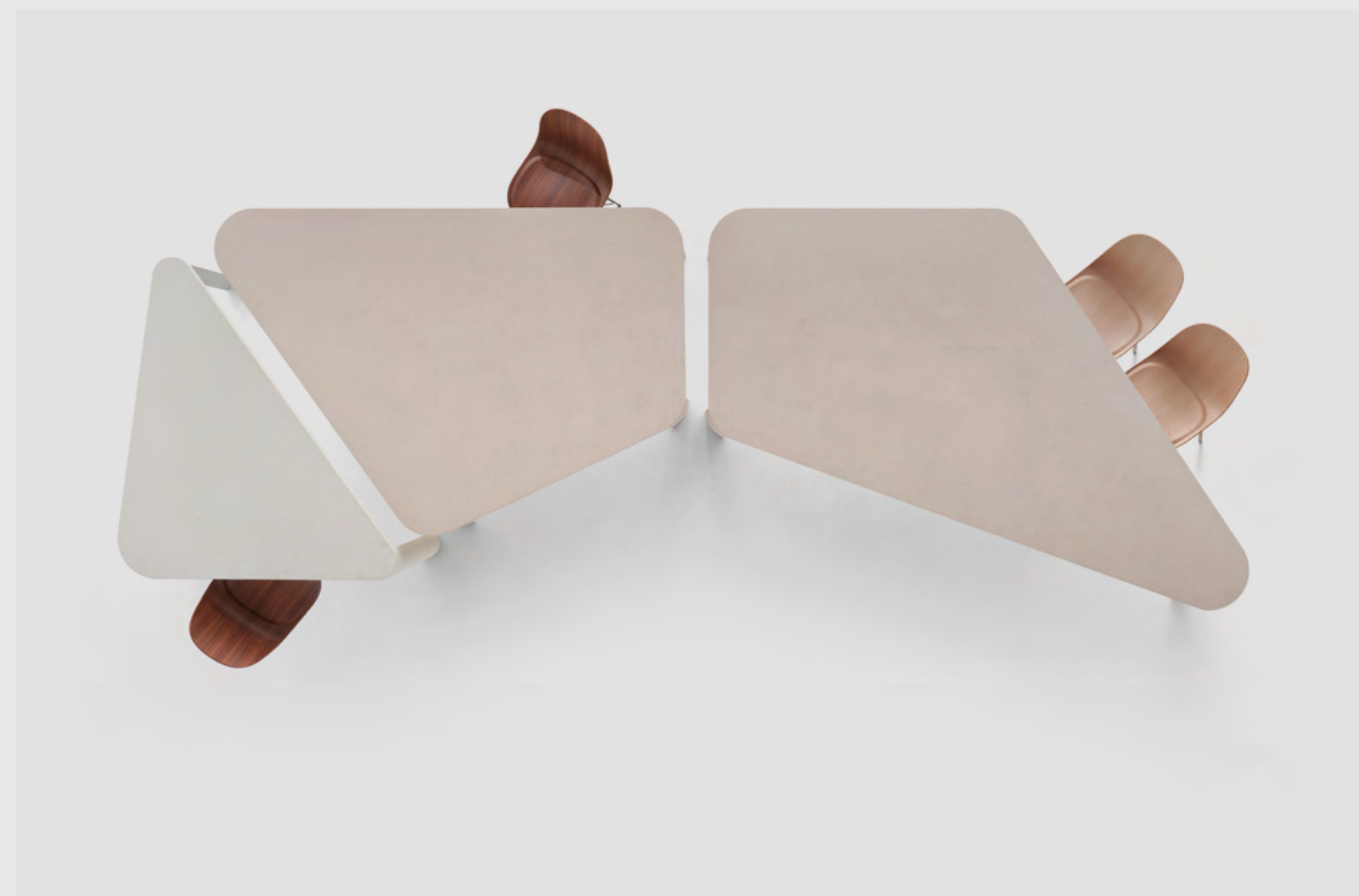
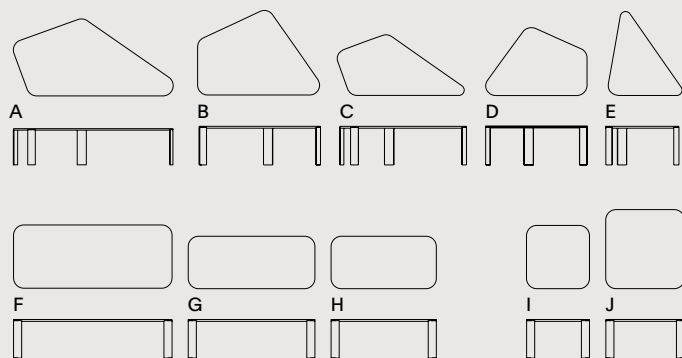



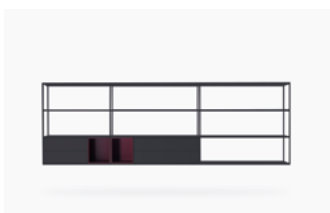

Minima 3.0 Hanging



Cosy Curve



Rock Table Mini



Cantle





← Edo chair consists of circular-section legs with a tapered profile, while the elliptical-section

back is a distinctive detail in the simple design.

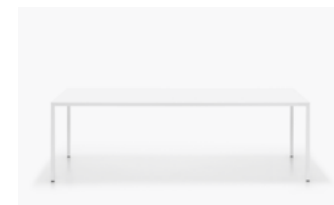

Tense Material

MDF Italia



Edo

News book



Pentagramma



## Tense

## Collection

Designed by Piergiorgio & Michele Cazzaniga

## Finishing

EN Technology and material innovation are distinguishing features of MDF Italia, the result of constant experimentation. Tense Material reflects this philosophy, exploring a variety of materials ranging from resins to wood to reconstructed stone. A table that changes its skin according to the context, offering unique visual and tactile experiences.

IT La tecnologia e l'innovazione dei materiali sono tratti distintivi di MDF Italia, frutto di una costante sperimentazione. Tense Material riflette questa filosofia, esplorando una varietà di materiali che spaziano dalle resine al legno, fino alle pietre ricostruite. Un tavolo che muta la sua pelle in base al contesto, offrendo esperienze visive e tattili uniche.



### Wood

Natural Oak X085	Carbonised X094	Fine Wood Italian Walnut X119
Heritage Black Stained Oak X206	Heritage Natural Oak X207	

### Reconstructed Stone\*

White Calce X131	Black Slate X132	Yellow Onyx X133
Pink Onyx X134	Serena X084	Brick Red X160
Sage Green X161		

### Solid surface/Matt Fenix top

White X035	Medium Grey X021	Black X022
---------------	---------------------	---------------

### Goffered Matt Painted \*\*

White X124	Corten X128	Black Iron X130
---------------	----------------	--------------------

\*Available for outdoor too.

\*\*Outdoor



EN The latest addition to the Tense family, a table designed in 2009 by Piergiorgio and Michele Cazzaniga, it somehow represents a leap into the past, reviving an ancient craft tradition. In the new Tense Material Heritage, the natural or black painted oak table top is finished with a handmade process known as 'sgorbiatura' (wood hand carving). This technique involves carving the wood in an irregular manner to achieve a wavy effect and offer an intensely tactile experience. This meticulous process – which requires several hours of work for each table – completes a frame that embodies the technological and industrial innovation that enabled it to reach considerable dimensions.

IT L'ultima novità nella famiglia Tense, tavolo progettato nel 2009 da Piergiorgio e Michele Cazzaniga, rappresenta in un certo senso un salto nel passato, con il recupero di una tradizione artigiana antica. Nel nuovo Tense Material Heritage, il piano del tavolo, in legno rovere naturale o verniciato nero, viene rifinito da una lavorazione fatta a mano detta "sgorbiatura". Questa tecnica consiste nell'intagliare il legno in modo irregolare per ottenere un effetto ondolato e offrire un'esperienza intensamente tattile. Un processo così minuzioso – che richiede diverse ore di lavoro per ciascun tavolo – va a completare un telaio che è invece espressione dell'innovazione tecnologica e industriale; la stessa che gli consente di raggiungere dimensioni considerevoli.

## Tense Material

## Heritage

UPDATE

Designed by Piergiorgio & Michele Cazzaniga



Dining table H73	A	D80 L140, 160		
		D90 L180, 200, 220, 240		
		D100 L200, 220, 240, 260, 280, 300		
		D120 L240, 260, 280, 300, 360, 400		
		D150 L200, 240, 300, 360, 400		
		D100 L100		
		D120 L120		
		D150 L150		
		Coffee table H45	B	D80 L140, 160
				D100 L100
D120 L120				
Low table H35	C	D120 L120		
		D150 L150		

A	Dining table	H73
B	Coffee table	H45
C	Low table	H35





EN The Edo chair collection is an ode to traditional craftsmanship. Formed of solid wood, the structure is designed as a frame to which different fabric or leather seat solutions can be attached, making it versatile and suitable for different settings. Featuring a sleek design inspired by Japanese aesthetics – the chair is named after ancient Tokyo –, it consists of circular-section legs with a tapered profile, while the back, in contact with the body, has an elliptical section that is more pleasant to the touch, which is also a detail with a distinctively simple design. The legs and crosspieces are interlocking, so that all the elements that define the chair's style are also functional and indispensable to its construction.

IT La collezione di sedie Edo è un inno alla tradizione artigianale. In legno massello, la struttura è concepita come un'ossatura a cui si possono fissare diverse soluzioni di seduta, in tessuto, pelle o cuoio, che la rendono trasversale e adattabile a diversi ambienti. Con una linea essenziale che si ispira all'estetica giapponese – prende infatti il nome dall'antica Tokyo –, si compone di gambe a sezione circolare dal profilo affusolato, mentre lo schienale, a contatto con il corpo, presenta una sezione ellittica, più piacevole al tatto, che risulta essere anche un particolare distintivo nella semplicità del disegno. Gambe e traversi si assemblano a incastro, per cui tutti gli elementi che contraddistinguono il linguaggio della seduta sono allo stesso tempo elementi funzionali, indispensabili alla sua costruzione.

## Edo

## Chair

Designed by Tommaso Caldera

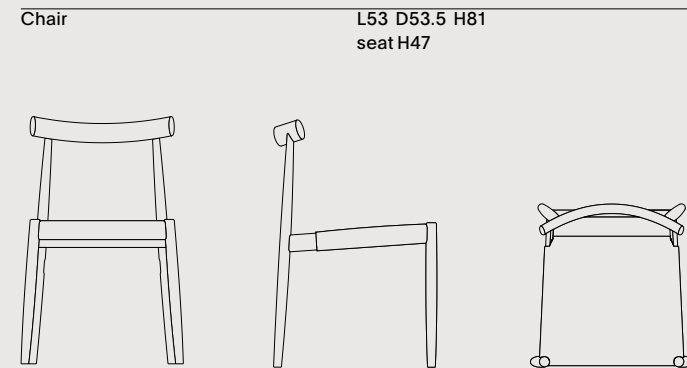





NEW!

Peggy

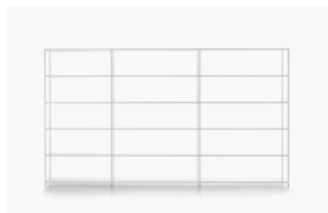

Minima 3.0



Tatami



Flow Low Table

→ The fabric wraps around the entire product and is tailored to enhance its shape.



Peggy

50



Tatami

Concepthouse



Flow Low Table

N.1





EN The Peggy armchair interprets a strong market trend: the taste for a "soft home". With its curvy, enveloping design, this chair conveys a sense of security, protection and cosiness, while breaking away from its historical context to become an iconic piece defined by its pure contours. "Peggy is an armchair that we feel we know," comments Gio Tiroto, "but have never encountered."

Made of tubular steel and recycled foam, it consists of just two parts: a base-back and a seat, held together by a fastening system that makes it easy to disassemble. Thanks to these elements, the back makes it both light and dynamic, as well as curvy and comfortable.

IT La poltrona Peggy interpreta una forte tendenza del mercato: il gusto per la "casa morbida". Con forme sinuose e avvolgenti, questa seduta trasmette senso di sicurezza, protezione e accoglienza, mentre si estranea dal contesto storico per diventare un pezzo iconico che trova la sua essenza nella purezza delle linee. "Peggy è la poltrona che ci sembra di conoscere – commenta Gio Tiroto – ma che non abbiamo mai incontrato".

Costruita in tubolare d'acciaio e schiuma riciclata, si compone di due sole parti: una base-schienale e una seduta, tenute assieme da un sistema di fissaggio che consente un'agevole smontaggio. Grazie a queste, lo schienale compie lo sbalzo che la rende dinamica e leggera, mentre al contempo risulta curvy e confortevole.

## Peggy

## Armchair

Designed by Gio Tiroto

Armchair	L110 D89 H74	A
fixed version/swivel base	seat H39	
Pouf	L60 D60.5 H38	B

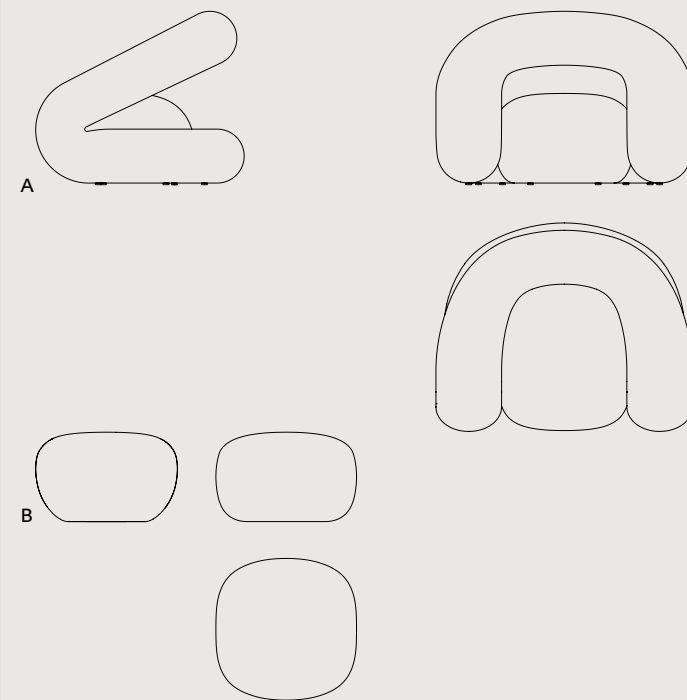

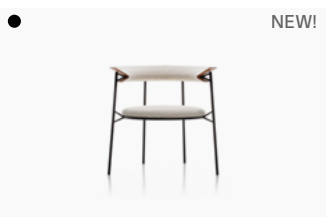

Cantle



← Rock Table is a family of indoor and outdoor tables with an elegant, fluid silhouette, characterised by a solid central conical base and a thin top that appears to float.



Edo



Rock Table Maxi

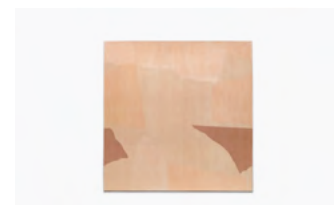

Frammenti

→ The Cantle structure is made of tubular metal in different diameters and powder-coated in matt graphite grey.



Cantle



Tatami





EN Equestrian inspiration underlies the Cantle collection. The term 'cantle' refers to the rear part of the saddle, which is usually curved and provides the rider with a safe and comfortable seat. In the seat designed by Lavit, the back thus assumes the form of the arc of a circle, which embraces the body and determines its posture. Supported by a steel frame that traces a strikingly sophisticated silhouette, both the back and seat are anchored to V-shaped brackets. This same element not only characterises the collection, but also makes it possible to reduce material consumption by removing the padding at the rear of the back: a detail enhanced by the double-sided upholstery made of leather and fabric sewn together, a savoir-faire element that evokes sartorial refinement.

IT L'ispirazione equestre è alla base della collezione Cantle. Il termine "cantle" indica infatti la parte posteriore della sella, solitamente curva, che fornisce al cavaliere un sedile sicuro e confortevole. Così, nella seduta progettata da Lavit, lo schienale assume la forma di un arco di circonferenza, che abbraccia il corpo e ne determina la postura. Sorretti da un telaio in acciaio che delinea una silhouette grafica e sofisticata, sia lo schienale sia il sedile sono ancorati a staffe a forma di "V". Questo stesso motivo non solo connota la collezione, ma permette di ridurre il consumo di materiale svuotando l'imbottitura nella parte posteriore dello schienale: un dettaglio esaltato dal rivestimento double-face in cuoio e tessuto cuciti assieme, con savoir-faire che evoca raffinatezze sartoriali.

## Cantle

## Armchair

Designed by Marco Lavit

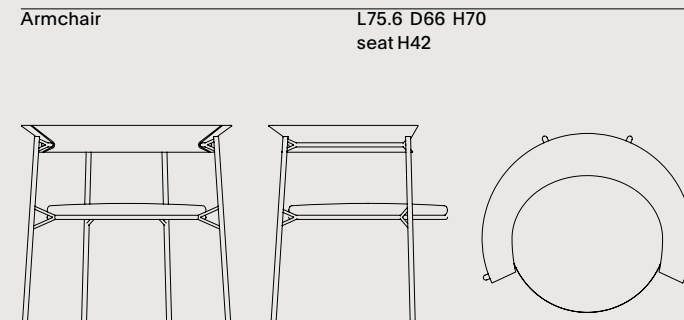



Array

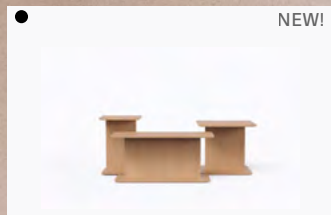

Array low table



Minima 3.0 Room Divider





← Pentagramma system, designed by Pitsou Kedem for MDF Italia, is further enriched with the introduction of the sideboard variant.



Array low table

MDF Italia



Array

News book



Pentagramma

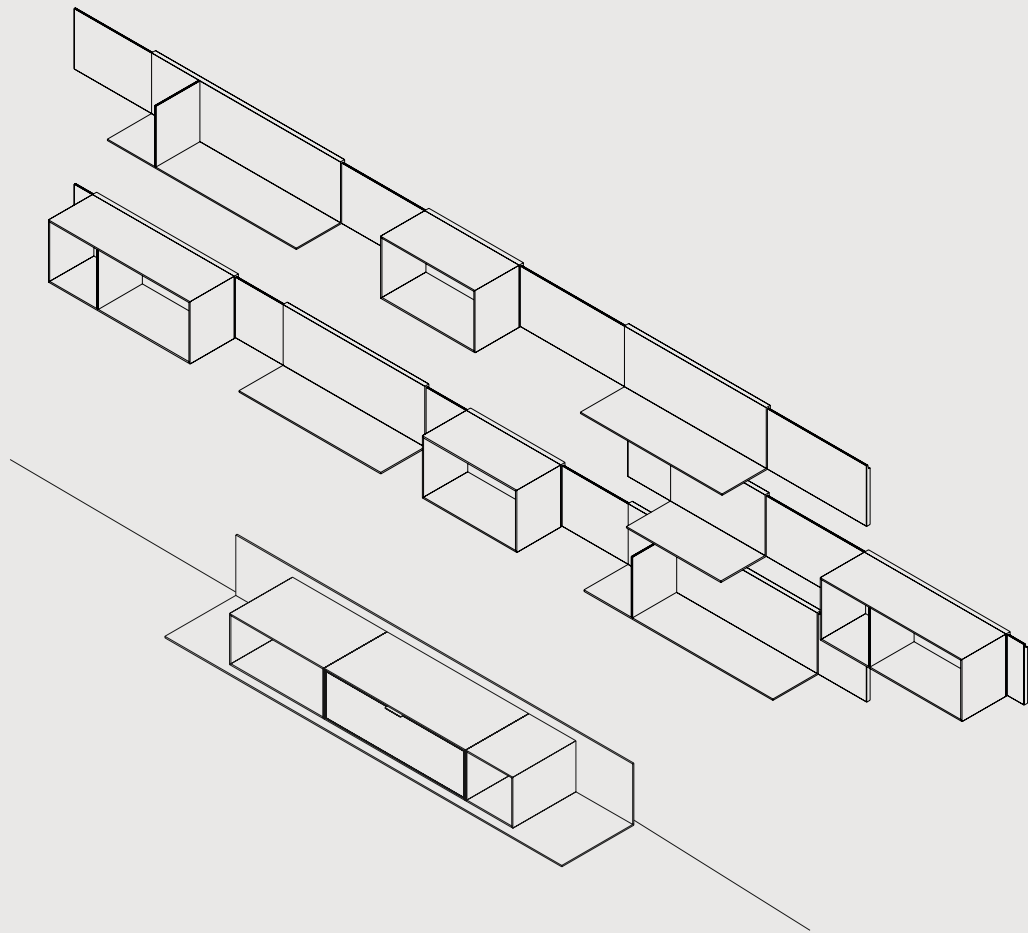

EN Pentagramma, the living system designed by Pitsou Kedem, further evolves with the introduction of new storage elements to meet the organisational needs of domestic and workspaces, from living areas to bedrooms to office environments. A wall-mounted panel, characterised by an aluminium core covered in essence in Canaletto walnut and bleached oak finishes, takes the shape of an "L" and accommodates storage units with a flap door and open compartments, available in the colours from the collection. Pentagramma's versatility is evident in its ability to be easily reconfigured over time, allowing the different elements to be moved as needed.

IT Pentagramma, il sistema a giorno firmato Pitsou Kedem, si evolve con l'introduzione di nuovi elementi contenitori per rispondere alle esigenze di organizzazione degli spazi domestici e lavorativi, dalle aree living alle camere da letto fino agli ambienti ufficio. Un pannello fissato a muro, caratterizzato da un'anima in alluminio rivestita in essenza nelle finiture noce canaletto e rovere sbiancato, e sviluppato a forma di "L", ospita contenitori in appoggio con anta a ribalta e vani giorno, proposti nei colori della gamma. La versatilità di Pentagramma si manifesta nella possibilità di essere facilmente riconfigurato nel tempo, consentendo di spostare i vari elementi a seconda delle necessità.

## Pentagramma System

Designed by Pitsou Kedem

UPDATE



Hanging	Back panels	L152, 202, 252 H33
	Shelves	L60, 90, 120 D28 H33
	Shelves with right or left dividers	L120 D28 H33
	Open unit	L30, 60, 90 D28 H33
Sideboard	Base elements	L152, 202, 252 D48 H42.3
	Open units	L30, 60 D40 H28
	Units with doors	L90, 120 D40 H28





Minima Sideboard



Peggy



Divide IT



Metodo

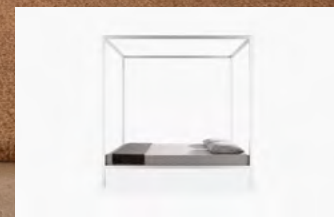

Aluminium Bed



← The Flow seating offers two shell designs, Chair and Armchair, with a wide range of finishes,

fabrics, and materials, which can be combined with five bases to generate a wide range of possibilities.



Bonnet



Flow collection



Random Wood



EN Launched in 2009 based on an idea by Jean Marie Massaud, Flow is a versatile family of chairs that has evolved over time to meet different needs, becoming one of the milestones of the MDF Italia collection. The restyling, 15 years after its inception, recaptures its iconic original design, adapting it to contemporary tastes without revolutionising its spirit. The body's glossy finish has now been replaced by a matt finish, accompanied by a completely new colour range. The upholstery and ergonomics have been further refined to provide even more enveloping comfort, while the wooden legs have been streamlined, creating a softer overall effect. Flow Chair and Flow Armchair are also available in a new solution with matt painted steel legs in 4 colour variants; also ideal for contract use.

IT Nata nel 2009 da un'idea di Jean Marie Massaud, Flow è una versatile famiglia di sedute declinata nel tempo per soddisfare diverse esigenze, divenendo uno dei pilastri della collezione MDF Italia. Il restyling, a 15 anni dalla nascita, distilla l'iconicità del suo design originale, adattandolo alla contemporaneità senza rivoluzionarne l'essenza. La finitura opaca della scocca sostituisce ora quella lucida e si accompagna a una gamma cromatica completamente rinnovata. L'imbottitura e l'ergonomia sono state ulteriormente perfezionate per garantire un comfort ancora più avvolgente, mentre le gambe in legno sono rese più fluide, conferendo maggior morbidezza all'insieme. Flow Chair e Flow Armchair sono inoltre disponibili nella nuova soluzione con gambe in acciaio verniciato opaco in 4 varianti di colore; ideale anche per l'uso contract.

# Flow

# Collection

UPDATE

Designed by Jean Marie Massaud

Chair	L56.5 D59 H80.5 seat H44
Armchair	L56.5 D58 H76.4 seat H44
Stool	L56 D56 H44, 65, 78
Pouf	L56 D56 H48

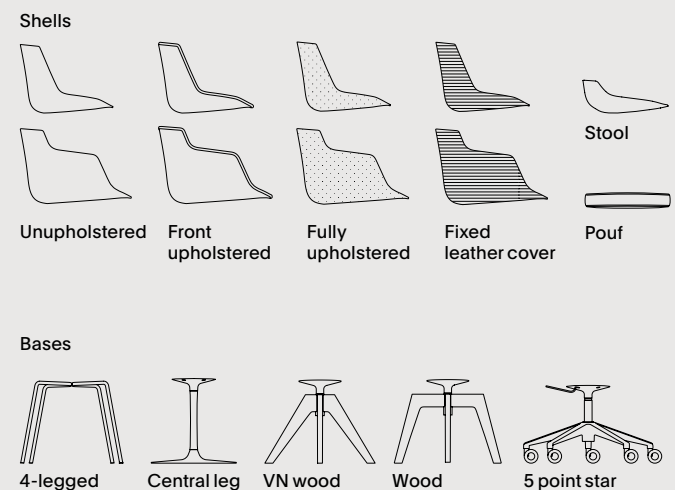



EN Particular attention was paid to sustainability: the new Flow is made of Makrolon® polycarbonate, 73% of which comes from renewable sources. This material maintains the same properties as virgin polycarbonate, but significantly reduces the environmental impact in terms of CO<sup>2</sup> equivalent. Furthermore, the commitment to the environment is underlined by the choice to use wood from sustainably managed forests and environmentally sustainable materials.

IT Particolare attenzione è stata dedicata alla sostenibilità: la nuova Flow è realizzata con polycarbonato Makrolon® di cui il 73% proviene da fonti rinnovabili. Questo materiale mantiene le stesse proprietà del polycarbonato vergine, ma riduce significativamente l'impatto ambientale in termini di CO<sup>2</sup> equivalente. Inoltre, l'impegno verso l'ambiente è evidenziato dalla scelta di utilizzare legni provenienti da foreste correttamente gestite e materiali eco-sostenibili.

Flow Sustainable Soul

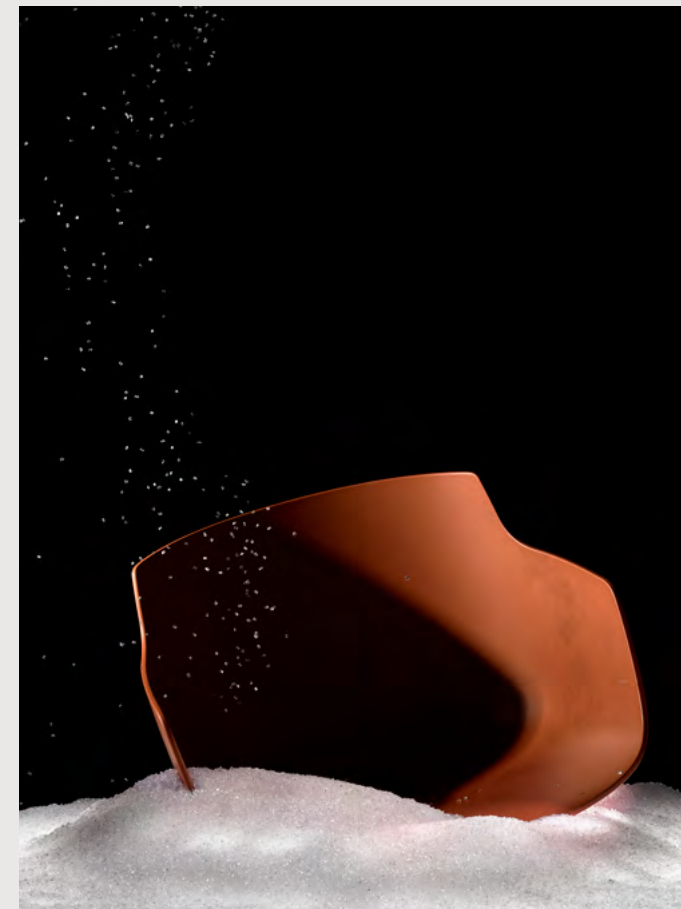
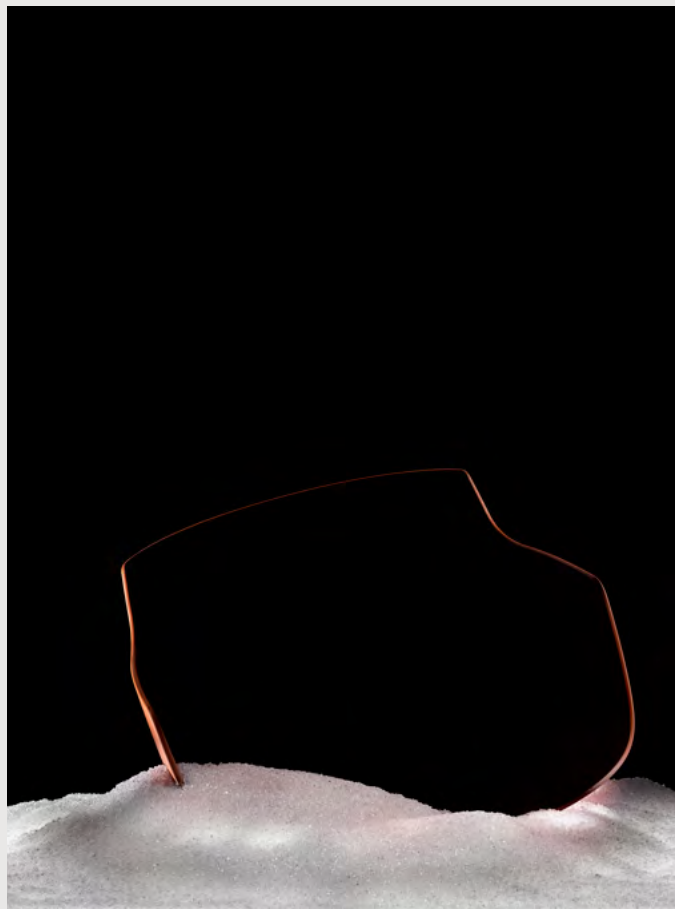

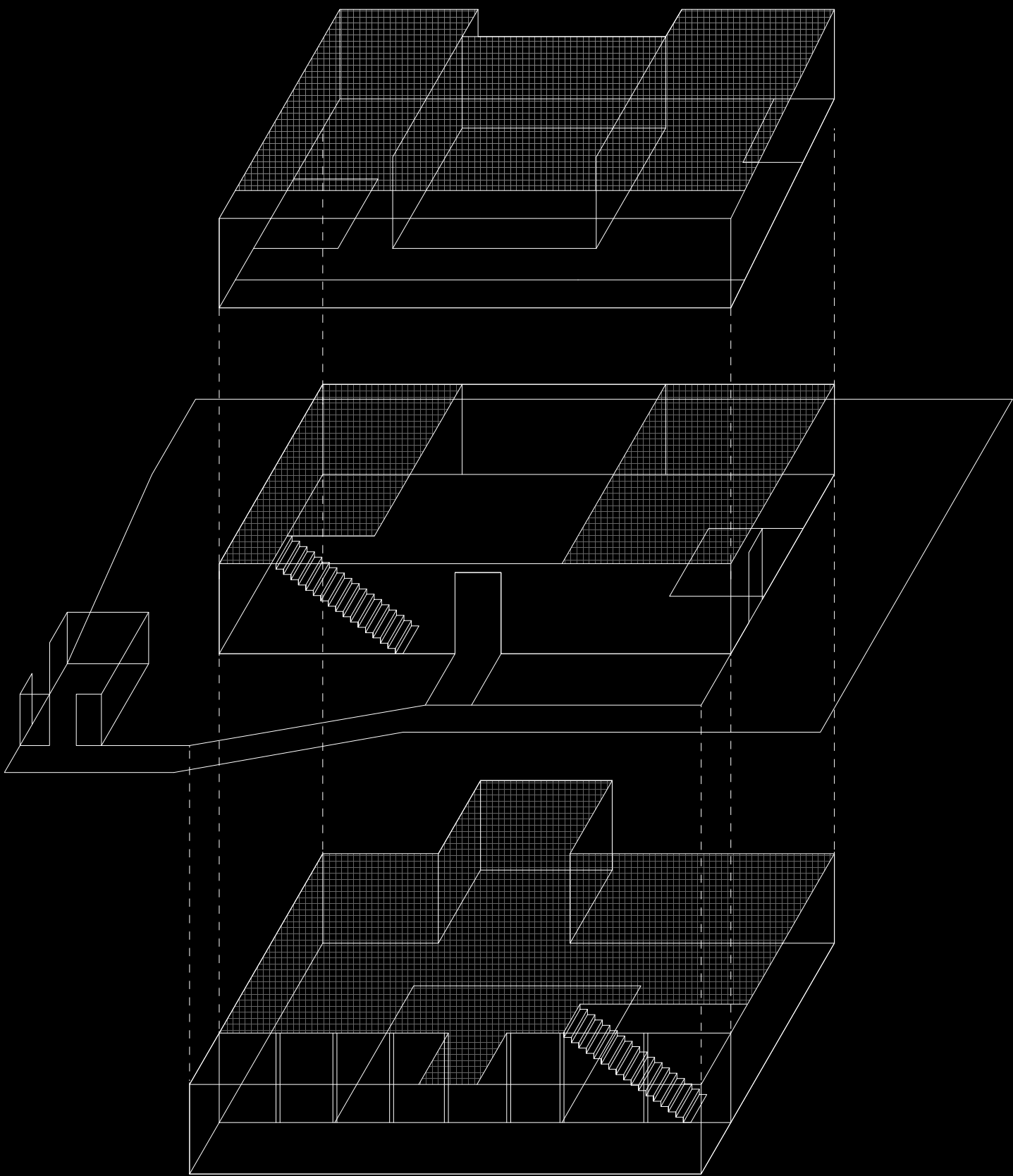

EN The essentiality of the volumes and the neutrality of the colours contribute to creating a suspended and exclusive atmosphere in this loft designed by Pitsou Kedem in the heart of a contemporary metropolis. From the concrete walls to the resin floors, from the metal panels to the natural stone details, all the rooms are characterised by a cultured and minimalist taste.

IT L'essenzialità dei volumi e la neutralità dei colori contribuiscono a creare un'atmosfera sospesa ed esclusiva in questo loft progettato da Pitsou Kedem al centro di una metropoli contemporanea. Dalle pareti in cemento ai pavimenti in resina, dai pannelli in metallo ai dettagli in pietra naturale, tutti gli ambienti sono caratterizzati da un gusto colto e minimalista.

# An urban

# loft

Concept house Architect N.2 Pitsou Kedem







→ Minima 3.0 is a versatile and adaptable furniture system capable of combining several functions.



Array low table



Array

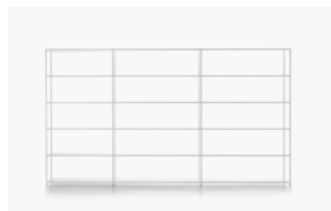

Minima 3.0





← NVL Table, a table with contemporary lines and characterised by a strong personality.



NVL Table



Neil Leather chair

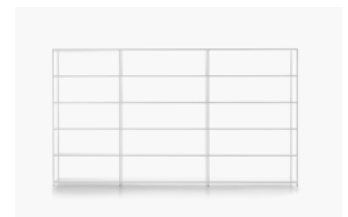

Minima 3.0

MDF Italia

News book

→ NVL Table extends its range with new finishes: matt or gloss Carrara white marble, matt or gloss Marquinia black marble, Calacatta gold marble,

matt or gloss Carrara white marble, matt or gloss Marquinia black marble.



NVL Table



Neil Leather chair

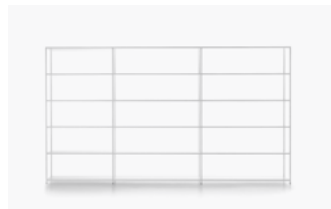

Minima 3.0



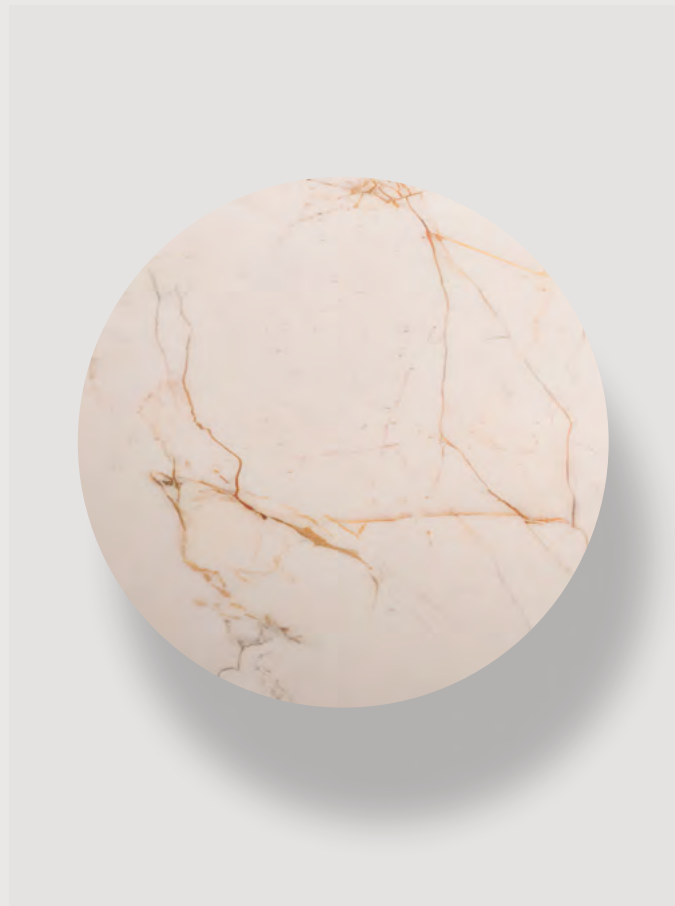

EN A table with contemporary lines and characters by a strong personality. The unique architecture of the NVL Table emphasises the stylistic elements that define Jean Nouvel's work: pure geometric shapes, formal lightness, graphic lines, rigour. The simplicity of the shapes harmoniously dialogues with the solidity of the material and plays with contrasts: the tabletop appears thin and light and seems floating above the base.

The central support is composed of two volumes that thin upwards and create two symmetrical bases that support the top, thus recalling the principle of trilith, a structure consisting of two vertical elements supporting a third element set horizontally across the top.

Simple and elegant, thanks to its round shape it encourages the conviviality among guests in dining rooms or living rooms. In its oval shape it fits perfectly in contract and working contexts, such as executive offices, meeting and representative rooms, encouraging the exchange of ideas between the participants. NVL Table is available in glossy or matt lacquered versions, in reconstructed stone and with a marble top: Calacatta gold, white Carrara and black Marquinia, both glossy and matt.

IT Un tavolo dalle linee contemporanee, connotato da una forte personalità. L'architettura unica di NVL Table mette in risalto gli elementi stilistici che caratterizzano il lavoro di Jean Nouvel: forme geometriche pure, leggerezza formale, graficità, rigore. La semplicità delle forme dialoga armoniosamente con la solidità del materiale in un gioco di contrasti: il piano del tavolo appare sottile e leggero e sembra galleggiare sopra il basamento.

Il sostegno centrale è composto da due volumi che si assottigliano verso l'alto e che creano due basi simmetriche a sostegno del top, richiamando così il principio del trilite, una struttura formata da due elementi verticali e un terzo appoggiato orizzontalmente.

Semplice ed elegante, grazie alla sua forma rotonda favorisce la convivialità degli ospiti in sala da pranzo o in soggiorno. Nella sua forma ovale si inserisce alla perfezione in contesti contract e working, come uffici direzionali, sale riunioni e di rappresentanza, incoraggiando lo scambio di idee tra i partecipanti. NVL Table è disponibile nelle versioni laccato lucido oppure opaco, in pietra ricostruita e con il top in marmo: Calacatta oro, bianco Carrara e nero Marquinia, sia lucidi che opachi.

## NVL

## Table

MARBLE UPDATE

Designed by Jean Nouvel Design



Round table with marble top H74	Ø150 base L50 D50	A
	Ø180 base L60 D60	B
Oval table with marble top H74	L200 D120 base L36 D36	C
	L250 D130 base L60 D36	D

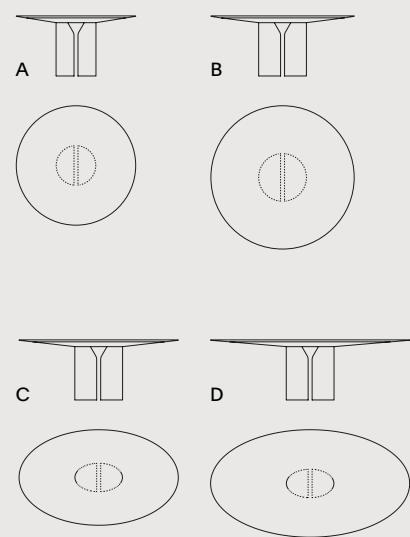





← The Press chair is available with 3 bases: 4 legs, butterfly base and 4 wooden legs.



Press collection



Bonnet

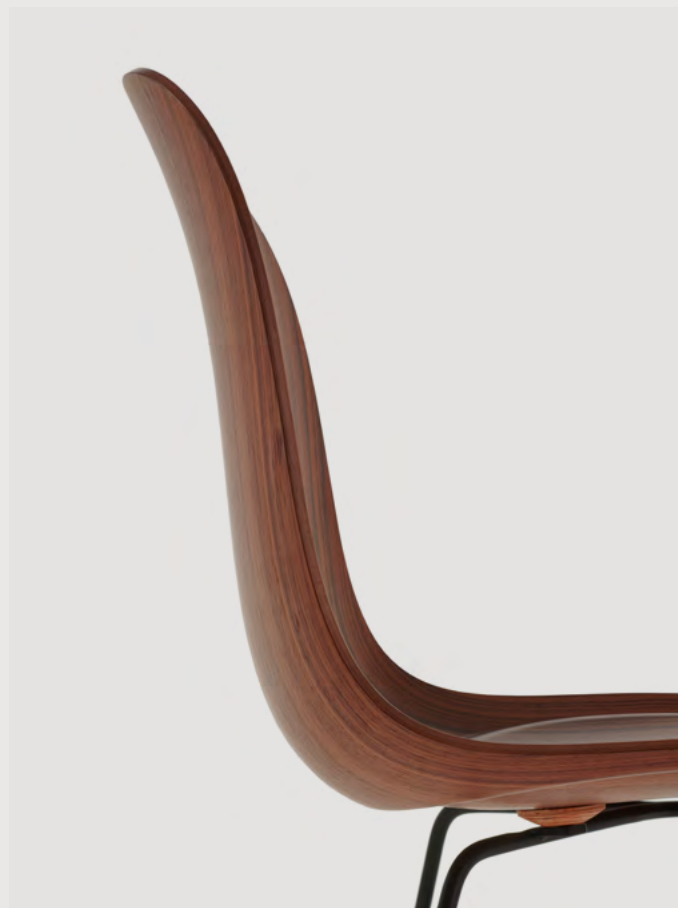

EN The Press chair epitomises research in seating design. "When working with any material," comments designer Benjamin Hubert, "we like to push its potential to the maximum." The result of two years of development, Press is named after the production process that allows complex shapes to be obtained from a three-dimensional veneer. The curvature not only makes the body stronger while keeping it light, but also offers a visual and tangible feeling of comfort. The wood also emulates the shapes of upholstered seats, revealing the design's innovative nature. Its polished and minimalist body is designed to stand the test of time and to fit into both residential and contract contexts, with a focus on the hospitality sector, including hotels, bars and restaurants. It can be combined with different types of bases, including legs made of curved wood, butterfly-shaped or stackable steel tube legs.

IT La sedia Press è emblema della ricerca nel design delle sedute. "Quando lavoriamo con qualsiasi materiale", dichiara il designer Benjamin Hubert, "ci piace spingere al massimo il suo potenziale". Frutto di due anni di sviluppo, Press prende il nome dal processo produttivo che consente di ottenere forme complesse partendo da un impiallacciato tridimensionale. La curvatura non solo aggiunge resistenza alla scocca, mantenendola al contempo leggera, ma offre anche una sensazione di comfort visivo e tangibile. Il legno emula inoltre le forme di sedili imbottiti, rivelando così la natura innovativa del progetto. La sua scocca levigata ed essenziale è pensata per resistere alla prova del tempo e per inserirsi sia in contesti residenziali che contract, con un'attenzione particolare al settore "hospitality", includendo hotel, bar e ristoranti. Può essere abbinata a diversi tipi di gambe, incluse quelle in legno curvato, a farfalla o in tubo d'acciaio impilabile.

## Press

## Chair

Designed by Benjamin Hubert

4-legged base stackable	L58.6 D55 H83 seat H46	A
Butterfly base	L47.3 D55 H83 seat H46	B
4-legged wood base	L48 D55 H83 seat H46	C





→ Duetto is available in two heights, in the fixed version or the 360° swivel version.



Duetto





EN Duetto, the new stool designed by 967arch for MDF Italia, has a versatile design and an ability to convey the company's identity in a product suitable for both contract and domestic settings. Duetto is composed of two thin metal blades under tension, supporting a curved polypropylene seat, creating a harmonious dialogue between the materials.

Featuring minimalist contours, a light design and a recognisable graphic style, Duetto is available in two finishes and two heights. This iconic yet functional stool has a strong visual presence, making it ideal as an informal seat for a variety of corporate, public and private settings.

IT Duetto, il nuovo sgabello progettato da 967arch per MDF Italia, si caratterizza per il suo design versatile e la capacità di trasmettere l'essenza dell'azienda in un prodotto adatto sia agli ambienti contract che domestici. Duetto è composto da due sottili lame in metallo in tensione, che sostengono una seduta sinuosa in polipropilene, creando un dialogo armonioso tra i materiali.

Caratterizzato da linee essenziali, leggerezza e un segno grafico riconoscibile, Duetto è disponibile in due finiture e due altezze. Questo sgabello, iconico e al contempo funzionale, si distingue per la sua forte presenza visiva, che lo rende ideale come seduta informale per una varietà di contesti aziendali, pubblici e privati.

## Duetto

## Stool

Designed by 967arch

### Finishing

Matt painted surface

White X053

Graphite Grey X054



Stool

L38 D38  
H66.7  
H76.7

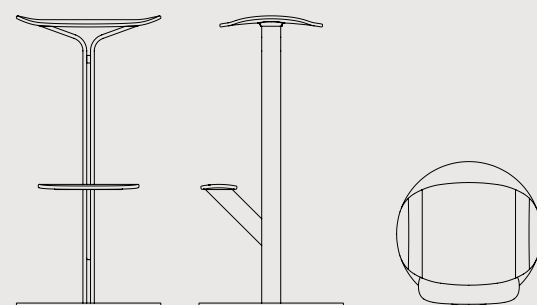



NEW!

Cantle

98



Yale Bed

Concept house



Cosy pouf

N.2

99

MDF Italia



Flow Low Table

News book



UPDATE

Pentagramma

→ Pentagramma system is further enriched with the introduction of the sideboard variant.

Its extraordinary flexibility and versatility allow the layout to be reconfigured over time,

thus offering the possibility to create infinite combinations to adapt to different functions and usage situations.



Pentagramma





Cosy Outdoor

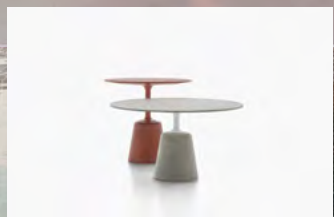

Rock Table Mini



Neil Twist armchair



Neil Twist chair



Rock Table collection



Twig



EN The Twig stool, designed by Gilli Kuchik & Ran Amitai, is distinguished by its sleek, sophisticated cylindrical shape composed of a few elements: a seat, a footrest and a base, all connected by a tubular metal structure. Twig's aesthetic is inspired by bicycle frames, featuring simple tubes cut at an angle and welded together. This assembly method allowed the designers to experiment with the angle of the corners, creating a cantilevered structure that generates an interesting visual tension while maintaining its solidity.

Available in two heights and two finishes, Twig is a stool which, when multiplied, creates a kind of forest in which each corner reveals a unique perspective of the object. Essential for social harmony, Twig is distinguished by a strong and bold identity that easily adapts to different residential or contract styles and contexts.

IT Lo sgabello Twig, progettato da Gilli Kuchik & Ran Amitai, si distingue per la sua forma cilindrica raffinata ed essenziale, composta da pochi elementi: una seduta, un poggiatesta e una base, tutti collegati da una struttura tubolare in metallo. L'estetica di Twig trae ispirazione dal telaio delle biciclette, con semplici tubi tagliati ad angolo e saldati insieme. Questo metodo di assemblaggio ha permesso ai designer di sperimentare con l'inclinazione degli angoli, creando così una struttura a sbalzo che genera una tensione visiva interessante, mantenendone al contempo la solidità.

Disponibile in due altezze e in due finiture, Twig è uno sgabello che, quando viene moltiplicato, dà vita a una sorta di foresta, dove ogni angolo rivela un punto di vista unico dell'oggetto. Essenziale per la convivialità, Twig si distingue per un'identità forte e decisa che si adatta facilmente a diversi stili e contesti residenziali oppure contract.

## Twig

## Stool

Designed by Gilli Kuchik & Ran Amitai

### Finishing

Matt painted surface

White X053

Graphite Grey X054



### Stool

L39 D39  
H67  
H78

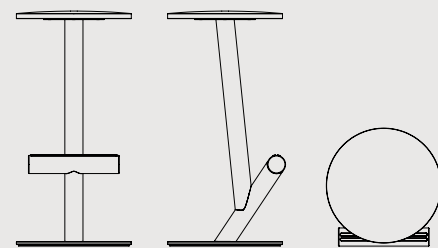

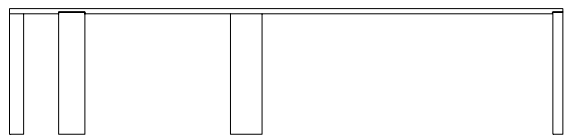
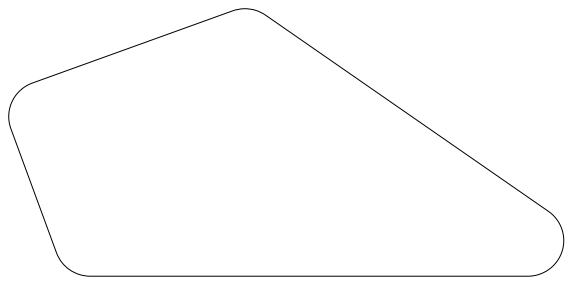

# Technicals

## Array sofa system



Design	Snøhetta	
Straight module with backrest	L32 D96 H68 seat H40	A
Module for external curve	L40 D96 H68 seat H40	B
Module for inside curve	L40 D96 H68 seat H40	C
Straight pouf module	L32 D96 H40	D
Curved pouf module	L40 D96 H40	E
Straight armrest module	L32 D96 H50	F
Curved armrest module	L40 D96 H50	G
Coffee table S	L32 D32 H44	S
Coffee table M	L45 D45 H39	M
Coffee table L	L74 D32 H34	L
Side table	L23 D52 H23	T

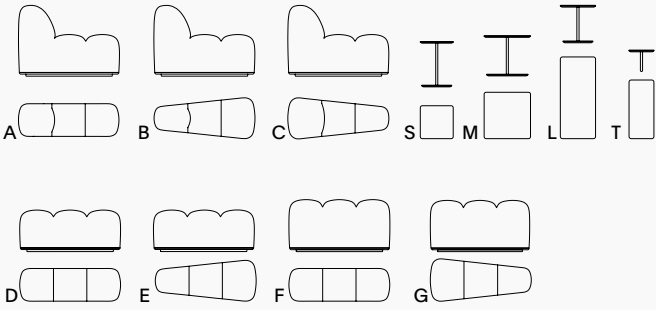

## Bonnet table



Design	Marialaura Irvine	
Shaped table	L300 D150	A
H73	L230 D160	B
	L240 D115	C
	L180 D130	D
	L140 D160	E
Rectangular table	L300 D120	F
H73	L240 D100	G
	L200 D100	H
Square table	L120 D120	I
H73	L150 D150	J

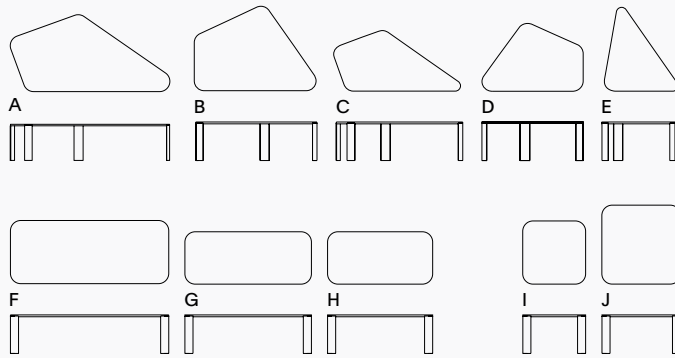

## Flow collection UPDATE



Design	Jean Marie Massaud
Chair	L56.5 D59 H80.5 seat H44
Armchair	L56.5 D58 H76.4 seat H44
Stool	L56 D56 H44, 65, 78
Pouf	L56 D56 H48

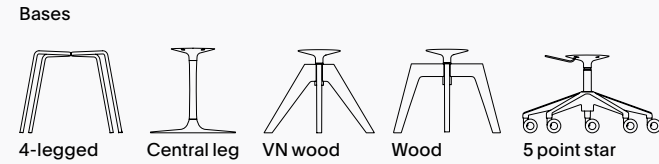
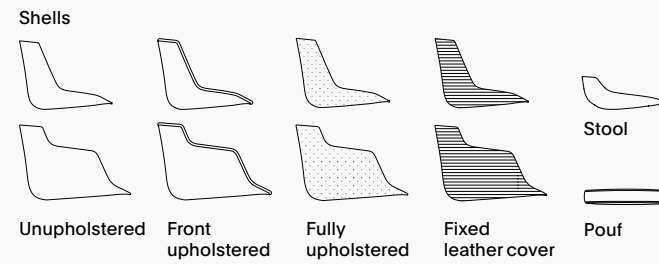

## NVL Table marble version UPDATE



Design	Jean Nouvel Design	
Round Table	Ø150	A
H74	base L50 D50	
	Ø180	B
	base L60 D60	
Oval Table	L200 D120	C
H74	base L36 D36	
	L250 D130	D
	base L60 D36	

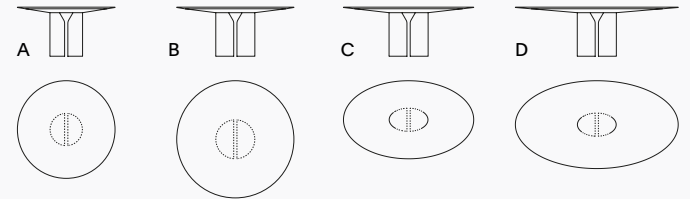

## Cantle armchair



Design	Marco Lavit
Armchair	L75.6 D66 H70 seat H42



## Duetto stool



Design	967arch
Stool	L38 D38 H66.7 H76.7

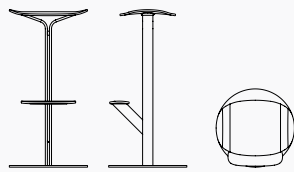

## Edo chair



Design	Tommaso Caldera
Chair	L53 D53.5 H81 seat H47

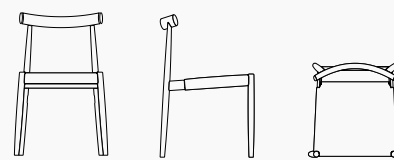

## Peggy armchair



Design	Gio Tiroto	
Armchair	L110 D89 H74	A
fixed version/swivel base	seat H39	
Pouf	L60 D60.5 H38	B

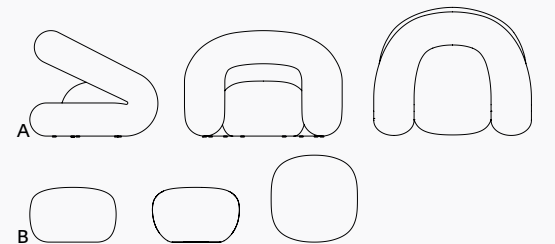



## Pentagramma system UPDATE



Design	Pitsou Kedem	
Hanging	Back panels	L152, 202, 252 H33
	Shelves	L60, 90, 120 D28 H33
	Shelves with right or left dividers	L120 D28 H33
	Open unit	L30, 60, 90 D28 H33
Sideboard	Base elements	L152, 202, 252 D48 H42.3
	Open units	L30, 60 D40 H28
	Units with doors	L90, 120 D40 H28

## Press chair



Design	Benjamin Hubert	
4-legged base stackable	L58.6 D55 H83	A
	seat H46	
Butterfly base	L47.3 D55 H83	B
	seat H46	
4-legged wood base	L48 D55 H83	C
	seat H46	

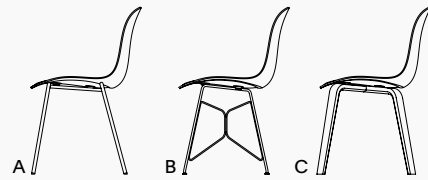

## Tense Material Heritage UPDATE



Design	Piergiorgio & Michele Cazzaniga		
Dining table H73	A	D80 L140, 160	
		D90 L180, 200, 220, 240	
		D100 L200, 220, 240, 260, 280, 300	
		D120 L240, 260, 280, 300, 360, 400	
		D150 L200, 240, 300, 360, 400	
		D100 L100	
		D120 L120	
		D150 L150	
	Coffee table H45	B	D80 L140, 160
			D100 L100
Low table H35	C	D120 L120	
		D150 L150	

A	Dining table	H73
B	Coffee table	H45
C	Low table	H35

## Twig stool



Design	Gilli Kuchik & Ran Amitai	
Stool	L39 D39	
	H67	
	H78	

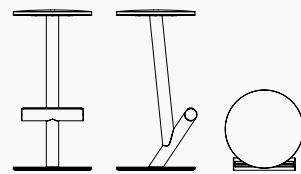

Credits

Concept

Graphic design  
and drawing

Studio CCRZ

Architecture

Pitsou Kedem Architects

Digital images

Nudesign

Mood and Styling

Enrico Pompili

Valentina Cameranesi

Photo still life

Lorenzo Cappellini Baio

Digital images Array

Snøhetta

Shestakovych Studio

Text

Cosimo Bizzarri

Lisa Cadamuro

Marta Galli

MDF Italia marketing dept.

MDF Italia Srl Società Unipersonale

Headquarters

Via Fratelli Cervi 4/A

22066 Mariano Comense (CO)

© 2024

MDF Italia all rights reserved

MDF Italia reserves the right to change,

at any time and without prior warning,

the technical specifications of any  
products illustrated in this catalogue.

[www.mdffitalia.it](http://www.mdffitalia.it)

Follow us



mdf italia



